



Access for All

[D E S I G N G U I D E L I N E S]

Publication of
National Commission Persons with Disability
www.knpd.org

Editors: Fred Bezzina, Joseph Spiteri

This publication was done with the aid of funds
from the Community Programme to Combat
Discrimination of the European Union

ISBN No: 99909-71-25-0

[F O R W A R D]

Since its inception in 1987, the *Kummissjoni Nazzjonali Persuni b'Dizabilità* (KNPD) has been guided by the Social Model of Disability, which views the major, root causes of disablement as social, man-made constructs. Thus, the primary energies of KNPD have not been aimed at changing disabled people, but at the eradication of social oppression through the removal of disabling barriers.

While disabling barriers can take on a multiplicity of different forms, lack of physical accessibility stubbornly remains one of the most serious barriers to social inclusion. It is thus an equally grave cause of social isolation for disabled people (a group which includes an ever-growing number of elderly people).

For this reason KNPD has always treated it as one of its priority areas of action. In fact, through the years KNPD has addressed the issue of physical accessibility in two ways, through: legislation (including enforcement) and education.

In the year 2000 the Maltese House of Representatives unanimously passed into law the *Equal Opportunities (Persons with Disability) Act*. At the same time, the then *Malta Planning Authority*, (now the *Malta Environment & Planning Authority*) entrusted KNPD with the responsibility of vetting all new project applications, or extensive modifications, of buildings 'of major use' to ensure that they complied with Access for All Guidelines. Also in 2000 KNPD issued a first edition of these guidelines. These have always been intended to serve a dual purpose: to give direction regarding one's legal obligations, and to educate.

The present second edition of the guidelines, built as they are on the past five years' experience, represent a significant advance and improvement on the first edition. KNPD is proud to have been instrumental in their genesis and publication.

Creating an inclusive environment requires a change of mentality, a change in traditional practices (which are not necessarily the best way forward) and conviction that an inclusive society is both desirable and attainable.

As a disabled person myself I augur that architects and entrepreneurs will view these guidelines positively and that any challenges presented by compliance to the guidelines will be addressed with common-sense, determination and a conviction that together we can create an inclusive society which does not disable, but enables us all, irrespective of ability, or disability.

Joseph M. Camilleri

CHAIR, Kummissjoni Nazzjonali Persuni b'Dizabilità

[C O N T E N T S]

Introduction	7
Layout and use of this document	8
Vetting Process	9
PART I – General Principles of Accessible Design	13
1.1 The Outside Environment and Approach to Facility	13
1.2 Entrances	16
1.3 Internal Environment	19
PART II – Design Guidelines	25
2.1 Surfaces Guidelines	25
2.2 Pavements and Pedestrian Crossings Guidelines	28
2.3 Parking Guidelines	30
2.4 Ramps Guidelines	33
2.5 Stairs Guidelines	36
2.6 Handrails / Grab rails Guidelines	38
2.7 Doors, Lobbies, Ante-Rooms and Corridors Guidelines	41
2.8 Lifts Guidelines	45
2.9 Sanitary Facilities / Changing Rooms Guidelines	48
2.10 Counters & Reception Desks Guidelines	53
2.11 Control Systems Guidelines	55
2.12 Lighting Guidelines	56
2.13 Signage Guidelines	57
2.14 Aural Environment Guidelines	60
Part III - Building Types Specific Design Guidelines	63
3.1 Industrial Buildings	63
3.2 Bus Shelters	65
3.3 Assembly Areas (e.g. Theatres, Auditoria, etc)	66
3.4 Business and Refreshment Buildings (e.g. Restaurants, Cafè's, Bars)	68
3.5 Facilities providing accommodation for the public (e.g. Hotels, Residences for the Elderly).	69
3.6 Residential buildings	70
3.7 Beaches and Swimming Pools	71
3.8 Offices (used solely as workplaces and providing no services to the public)	72

List of Figures

Figure 1: Details of tactile paving.	25
Figure 2: Layout of gratings	26
Figure 3: Accessible for All parking space dimensions	30
Figure 4: Parking for persons with disability layout	31
Figure 5: Details of ramps	34
Figure 6 : Ramp with 90 degree turn (Minimum dimensions of landings)	34
Figure 7: Ramp with 180 degree turn (Minimum dimensions of landings)	35
Figure 8: Details of handrails	38
Figure 9: Details of handrails flanking steps	39
Figure 10: Clear opening width of door	42
Figure 11: Minimum dimensions of lobbies.	43
Figure 12: Width of corridor and required turning circle	44
Figure 13: Internal lift car dimensions of an accessible to all lift	46
Figure 14: Details of accessible to all WC cubicle (plan)	51
Figure 15: Details of accessible to all WC cubicle (elevation)	51
Figure 16: details of accessible to all shower cubicle (plan)	52
Figure 17: details of accessible to all shower cubicle (elevation)	52
Figure 18: International symbol of access	58
Figure 19: International symbol indicating services for hearing impaired persons	58
Figure 20: Details of seating arrangements for wheelchair users in auditoria	66
Figure 21: Details of seating arrangements for wheelchair users in auditoria	67

List of Tables

Table 1: Potential for slip of surfaces	27
Table 2: Accessible for All parking spaces requirements.	31
Table 3: Maximum permissible gradients	33
Table 4: Position of controls	55
Table 5: Minimum lighting levels.	56
Table 6: Height of signs	57
Table 7: Colour schemes for sign boards.	58
Table 8: Provision of wheelchair spaces in auditoria and meeting spaces.	66

[INTRODUCTION]

In designing buildings it is important that everybody including persons with disability are able to access and use the internal and external facilities associated with the development, building or facility

Architecture should involve the creation of spaces for use by people. In the organisation of such spaces, shortcomings in design may create 'architectural barriers'. Architectural barriers are everywhere in existing buildings: in schools, shopping areas, workplaces and a large number of buildings that are intended for and are in fact used by the general public. The environment continues to hamper and frustrate the functioning of disabled persons, while most 'non-disabled' persons are unaware of the problem.

Within the existing building stock, providing access for all may require a number of alterations, including structural alterations.

The question of providing access for all in new buildings has deeper significance than merely providing means to negotiate physical barriers (e.g., ramps in changes of levels, etc.). New buildings should be designed in such a way that physical barriers would not exist as a matter of course. This requires a new mentality towards the design of buildings and building services.

A number of publications containing architectural design criteria for accessibility exist. However, these criteria are not uniform; they vary in standards and may give rise to some degree of confusion. This book is intended to aid in the design of all aspects of building and site development. This publication has been designed to incorporate the standards that will be adopted by the National Commission Persons with Disability (KNPD) in executing its responsibilities under the Equal Opportunities (Persons with Disability) Act, 2000. It includes graphical illustration of the standards contained in the text, for further ease of reference.

The objective of Access for All should be not only seen as a legal requirement, but one that enhances the usage of any development.

Fred Bezzina
Joseph Spiteri
Editors

[L A Y O U T A N D U S E O F T H I S D O C U M E N T]

This document is laid out in a manner to assist designers and all those concerned in determining the spatial layout and fitting of buildings. It is important that all the features relating to building development are designed in a manner that conforms to Access for All requirements.

The guidelines are divided into three parts:

Part I presents the general principles and guidelines of accessible design.

Part II provides the technical information regarding the design specifications that should be adopted to provide accessible features of a development.

Part III deals with accessibility in specific types of buildings and facilities.

Part I of the guidelines is divided into three sections. These refer to:

- a) the outside environment and the approach to buildings,
- b) the entrance to buildings and
- c) the internal environment.

Part II consists of 14 sections that provide technical information regarding various developments and building elements.

Part III contains guidelines regarding specific types of buildings grouped in 8 sections.

In Part I of this manual reference is made to the specific design guideline specifications that apply to the particular item and which can be found in Part II.

Features that should be incorporated at the planning stage of the structure of a building or development, (i.e. typically at planning application stage), are marked with the symbol (✓) in the right column to provide guidance regarding those features that should be checked for accessibility at the planning stage. Those characteristics of a development as well as all the other recommendations featured in the guidelines should be implemented to provide a truly accessible to all environment and would typically be checked to ensure accessibility at the practical completion of a project (typically at compliance / clearance stage in the planning process).

Unless otherwise stated, all measurements are in mm.

Some drawings of projects at the planning stage, may refer to features which although not marked in the far right hand next to the relevant item in the guidelines, are, nonetheless, included in the proposal at the planning stage. In this case, where such details have been included at the planning stage, they should be vetted for conformity to the guidelines.

The following section describes the vetting process adopted by the KNPD.

[V E T T I N G P R O C E S S]

The vetting process is done according to these Access for All Design Guidelines on all buildings that are accessible to the public and as listed in circular PA 3/99 issued by the Malta Environment and Planning Authority (MEPA), or any other document in force at the time.

The process of vetting is described in the Flowcharts 1, 2 and 3.

As a rule KNPD, submits its written opinion within the 30 day consultation period granted by MEPA. In certain circumstances, such as the vetting of large developments, KNPD may request an extension of this period.

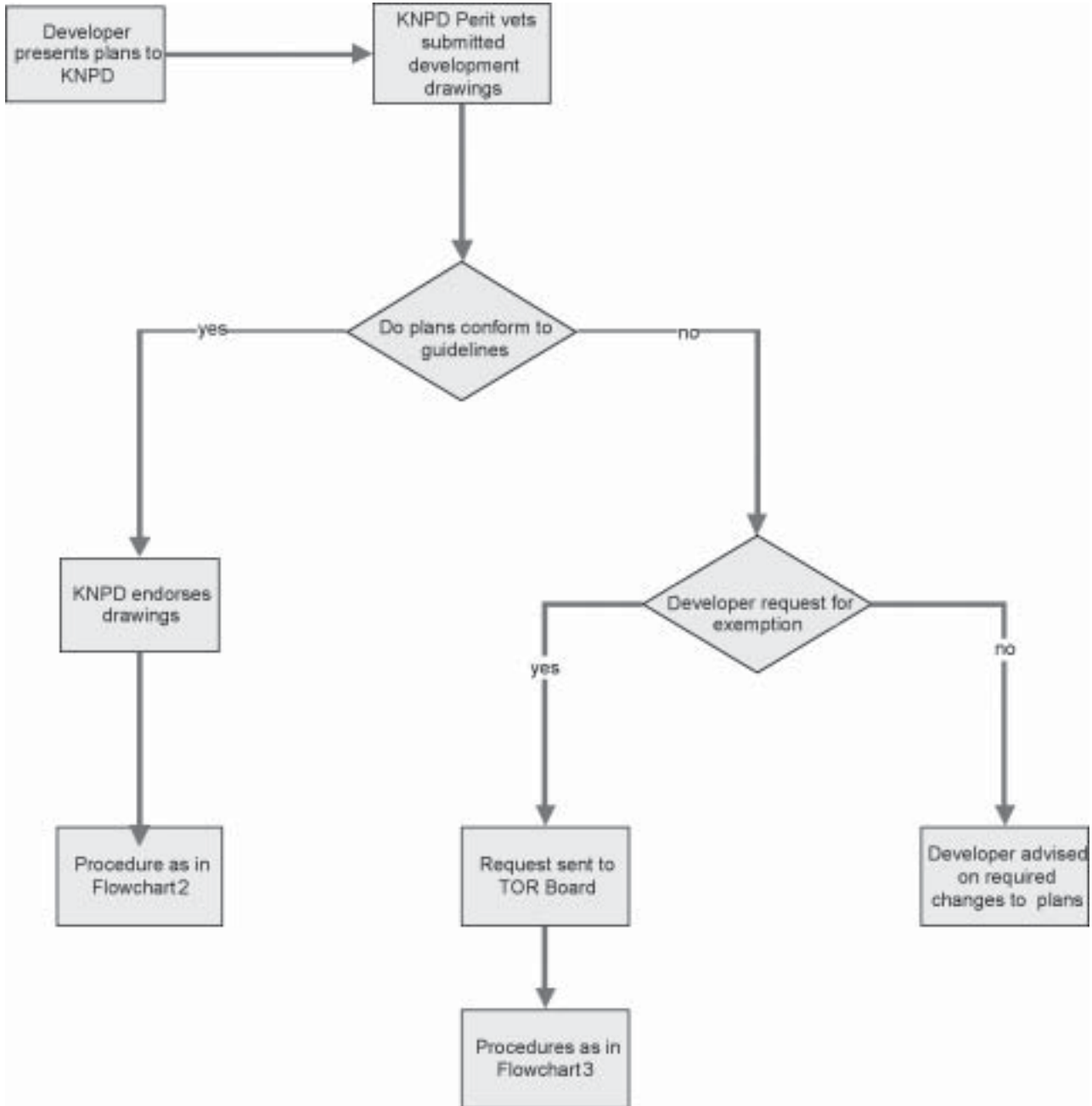
In order to facilitate the formal consultation process, KNPD is ready to hold pre submission meetings with developers and their architects prior to submission of development permission applications to MEPA.

According to the Equal Opportunities Persons with Disability Act, a developer may request an exemption on grounds of reasonableness. Such requests are considered by a Board set up for this purpose by the KNPD.

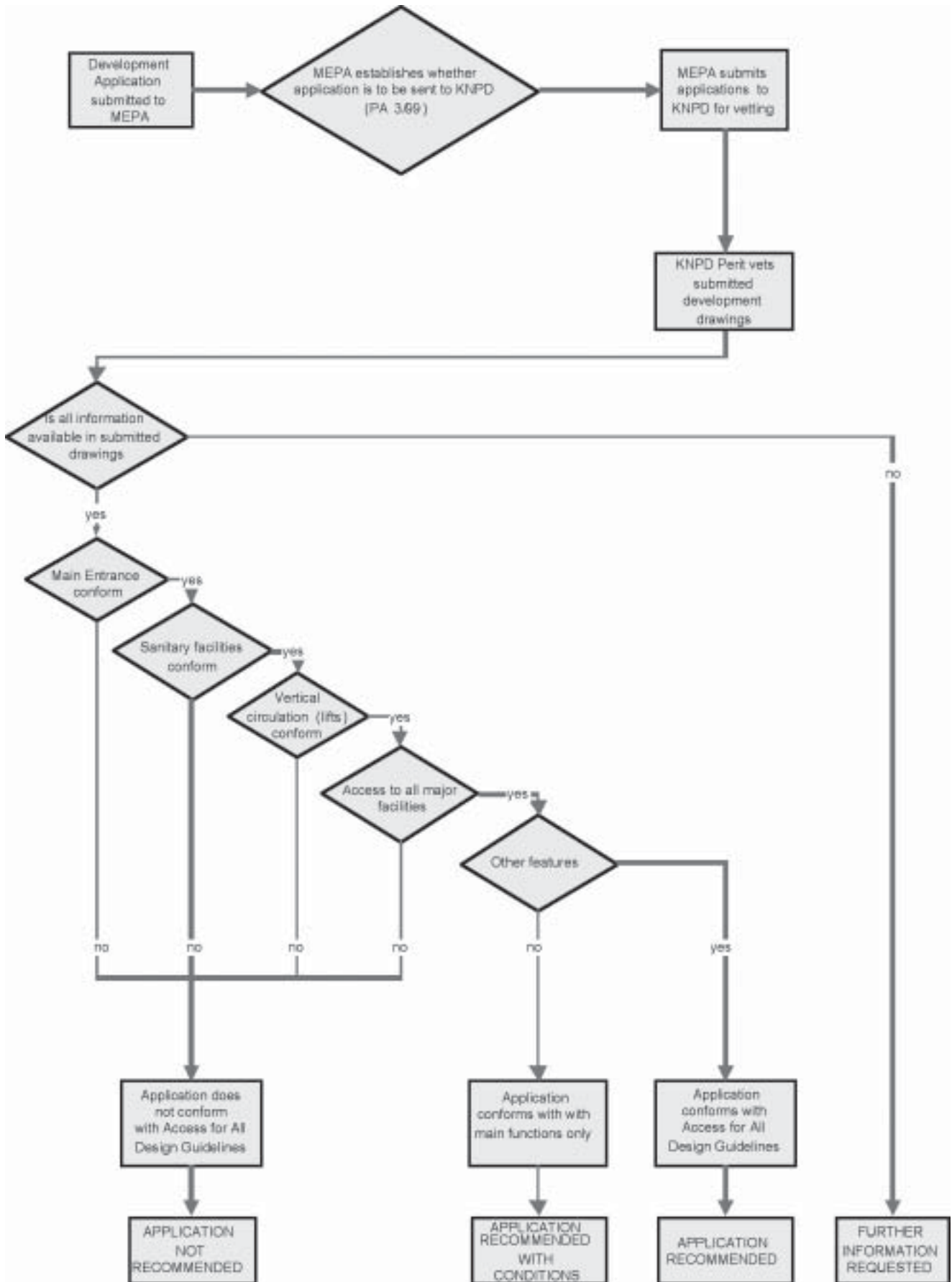
Industrial buildings and small business developments are subject to exemptions according to the Test of Reasonableness (TOR) provisions of the Equal Opportunities Act (Persons with Disability) (Act I: 2000) and as detailed in Part III of this document and are vetted in accordance with these exemptions.

Developers may request the consideration of the Board, regarding a proposed development application, prior to submission to MEPA.

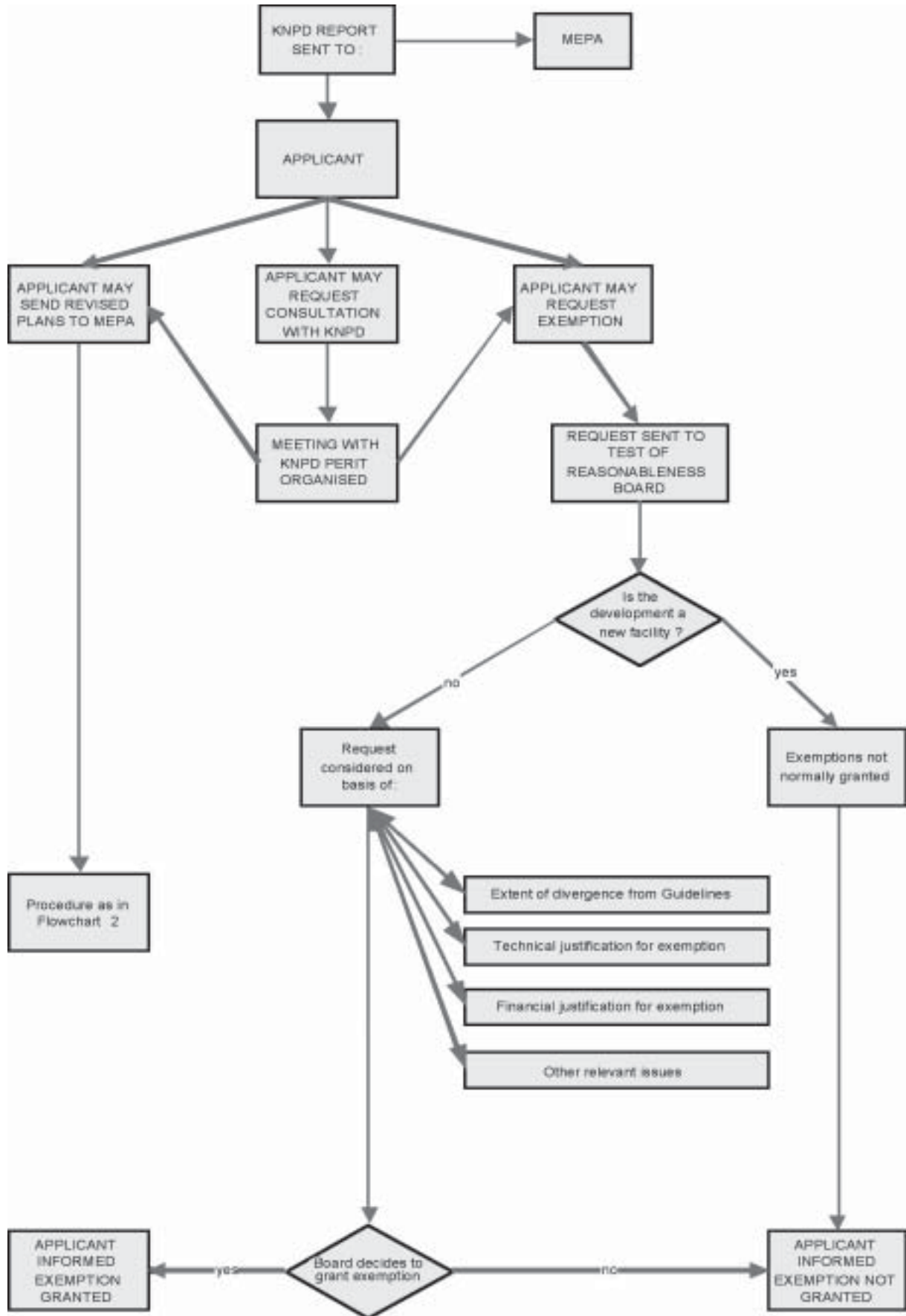
Flowchart 1: Pre Submission Consultation of Development Plans by KNPD



Flowchart 2: Vetting of Development Permission Applicants by KNPD



Flowchart 1: Procedure when application is not recommended by KNPD



[P A R T I] General Principles of Accessible Design

1.1 The Outside Environment and Approach to Facility

Items
assessed
at design
drawing stage

General Considerations

- 1.1.1 The treatment of the site of a building or facility and the relative locations of the entrances, service entrances and points of arrival contribute to the ease of use of the building by persons with disability.
- 1.1.2 A suitable means of entry into the area around a building is to be provided for persons with disability where such outside areas form part of the development. These outside areas shall be accessible to all.
- 1.1.3 Continuous unobstructed access routes to and around buildings should be provided in the following locations:
- From a public thoroughfare, pavement and designated car parking spaces to the principal accessible entrance.
 - Externally between the principal accessible entrances and any other subsidiary entrances and buildings if external circulation is required between them.
 - Between buildings in a complex.
 - To and from facilities associated with, and in immediate vicinity of, buildings.

Access Routes/External Paths

- 1.1.4 The minimum unobstructed width of an access route should be a least 1000mm wide.
- 1.1.5 Access routes should not contain steps or other features, which constitute a barrier to persons with disability.
- 1.1.6 Access routes should not contain turnstiles, revolving doors, escalators or other features, which constitute a barrier to persons with disability. The position of the following elements may also cause an obstruction if placed within an access route: utility (telephone, electrical etc.) poles, bus stops; street furniture such as bins, pots, and benches; as well as temporary ones erected during feasts and other public manifestations.
- 1.1.7 The cross fall gradient across a level access route must not exceed 1:50 except when associated with a dropped kerb.

See guidelines on Surfaces

- 1.1.8 Pavement, kerbs and ramped kerbs should be designed to be accessible to all.
- 1.1.9 The swing of doors and windows should not extend into an access route.
- 1.1.10 Hazard protection should be provided if objects project more than 100mm in to an access route and their lower edge is more than 300mm above the ground. Hazard protection should take the form of a kerb or other solid barrier so that a blind or partially sighted person can detect the hazard using a cane.
- 1.1.11 Bushes and trees planted close to pedestrian areas, especially the overhanging parts of such vegetation, should not cause an obstruction to pedestrians.
- 1.1.12 Walking long distances is tiring. Being able to take rests expands the disabled person's range of action. Hence access routes on level ground should have resting places not more than 50m apart.
- 1.1.13 Tactile surface strips should be employed to differentiate between the pedestrian footway and vehicle carriageway where the footway is flush with the carriageway.

See guidelines on Pavements and Pedestrian Crossings

Parking

- 1.1.14 Car parking, setting down and garaging are important activities at the beginning or the end of journeys. Setting down points may be on- or off-street and must be associated with an accessible route to the principal accessible entrance. Also parking lots must take into consideration the particular needs of persons with disability.

See Guidelines on Parking

Sign Boards

- 1.1.15 Sign boards should be located as not to cause an obstruction and to allow a free unobstructed route no less than 1000mm in width.
- 1.1.16 Signs, other than official traffic and direction signs regulated by ADT should have the following characteristics:
- Type should have lines of uniform thickness
 - Type should have no flourishes
 - Underlining should not be used
 - A large contrast between letters and their background, black lettering on a yellow background makes for good readability.
- 1.1.17 Sign boards should be affixed having the bottom edge at least 2m above the ground level.

See guidelines on Signage

Different Levels

- 1.1.18 Where different levels occur in the outside environment especially when it hinders the approach to the building or the use of a particular feature (example parking facility), ramps and/or steps including all necessary features such as handrails should be provided.

See guidelines on Ramps

See guidelines on Stairs

See guidelines on Handrails and Grab rails



Turning circles

- 1.1.19 A turning circle of 1500mm should be provided in all circumstances where a wheelchair is required to manoeuvre through a 90 degree or a 180 degree turn.



1.2 Entrances

Items
assessed
at design
drawing stage

General Considerations

- 1.2.1 Principal entrances to buildings and other facilities for public use should be accessible externally and internally for all users.

Entrances specifically provided for a particular purpose for example, for members of staff, should also be accessible to all and conform to the guidelines contained herein.

Unless suitably designed, the principal entrance to a building can often be a barrier to access for disabled people. The following factors should be taken into consideration in the design of the principal entrance to a building:

- The prominence and visual relationship of the entrance with its surroundings;
- The type of threshold needed to allow convenient wheelchair manoeuvre;
- The ease of operation of the principal entrance door;
- The minimum effective clear width through the doorway.



- 1.2.2 To be suitable as a means of access, the entrance should provide:

- Sufficient space for manoeuvres. (A turning circle of 1500mm should be provided in all circumstances where a wheelchair is required to manoeuvre through a 90 degree or a 180 degree turn.)
- Space outside the leading edge of the door to reduce the risk of wheelchairs striking a wall.



- 1.2.3 Access to all shall be provided through the main principal entrance.



- 1.2.4 If reasonable access through an alternative entrance may be accepted, if this is also intended for general use.



- 1.2.5 The entrance into a building should be level and flush with the floor / ground finish internally and externally so as not to present a trip hazard.



- 1.2.6 A new building, where it is reasonable to have an elevated ground floor (for example due to the presence of a semi basement construction), is also required to have an accessible to all principal main entrance. This may be provided via a ramp or via a platform lift. Where a platform lift is intended to form part of an accessible entrance route it must be located internally within the building fabric.



See guidelines on Lifts

See guidelines on Ramps

See guidelines on Stairs

See guidelines on Handrails and Grab rails

Lobbies

- 1.2.7 The dimensions and shape of an entrance lobby should allow a wheelchair user to be able to move clear of one door swing to push open the next door or reverse the wheelchair to pull it open. A space should also be provided for an assistant, if needed, to support a wheelchair user.

See guidelines on Doors, Lobbies, Ante-Rooms and Corridors



- 1.2.8 Door bells, entry phones / identification systems should be sited for approach and use from a wheelchair. Phones and identification systems should contain a light emitting diode display to enable people with impaired hearing to use them.

See guidelines on Control Systems



- 1.2.9 The principal entrance, particularly in the case of relatively large buildings, should incorporate a form of weather protection such as a canopy or recessed entrance unless freely accessible automatic doors are installed.



- 1.2.10 Hanging signs, lights, awnings and similar objects shall have a minimum clearance of 2m above the ground or finished floor level of the access route or entrance area.



Doors

- 1.2.11 The principal main accessible entrance door should be designed, marked or signed in such a way so that persons of different needs can readily identify it.



- 1.2.12 A distinction is made in the guidelines between the principal main accessible doorway providing access into a building, particularly from an outdoor area, and an internal door providing access between two spaces within a building. The former requires more generous space provisions and should have a minimum clear opening width of not less than 900mm. A clear opening width of 850mm is considered acceptable for the latter.



- 1.2.13 Revolving doors are not considered as adequate accessible entrance doorways unless specifically designed for persons with disability in terms of space and timing. Unless so specifically designed, an entrance fitted with a revolving door shall have an adjacent door conforming to the guidelines contained in this section.



- 1.2.14 Exit doors, particularly those for emergency egress, are as important as entrances and should conform to the guidelines indicated for principal main accessible doorways.



- 1.2.15 Contrast, luminance, ironmongery, opening devices, etc should be according to these guidelines.



See guidelines on Lighting

- 1.2.16 Emergency exits should be accessible to all. An emergency escape route for persons with disability or alternatively a smoke and fireproof refuge area for persons with disability who may be caught at the higher floors during an emergency such as fire should be provided



1.3 Internal Environment

General Considerations

- 1.3.1 A suitable means of access is to be provided for persons with disability in all areas. The layout of spaces and minimum dimensions of all circulation spaces and other facilities should be designed to allow easy and safe access by persons with disability including wheelchair users, ambulant disabled persons and persons experiencing visual and aural impairments.

Changes in level should be avoided wherever possible in the internal layout of buildings.

Clear signs indicating facilities should be provided.

Corridors and passageways need to have sufficient space to provide convenient access to rooms and if necessary to turn through 180 degrees. A turning circle of 1500mm should be provided in all circumstances where a wheelchair is required to manoeuvre through a 90 degree or a 180 degree turn.

All facilities and functions within a building should be accessible to all. Furniture layouts should be designed to provide an accessible to all environment.

- 1.3.2 The following guidelines apply to all buildings open to the public. Special conditions may apply to specific types of buildings indicated in Part 3 of these guidelines.

Vertical Circulation

- 1.3.3 Facilities and buildings that are constructed over two or more levels are required to have at least one 'accessible to all' lift.

See guidelines on Lifts

- 1.3.4 Each floor within a building should be level throughout. Where a change in level within a floor is unavoidable, a ramp or platform lift may be considered as a reasonable means of providing access for all within the floor.

See guidelines on Ramps

See guidelines on Lifts

Lifts

- 1.3.5 Lifts in an accessible to all environment may be conventional passenger lifts, vertical platform lifts or stair platform lifts.



- 1.3.6 Lifts are an essential amenity for disabled people in multi-storey buildings. These buildings should have at least one lift that is of sufficient size to be accessible by wheelchair users and should serve all floors.

See guidelines on Lifts



- 1.3.7 Platform lifts transfer persons on a guarded platform vertically from one level to another. Where it may be impractical to provide a passenger lift, a platform lift may constitute a reasonable alternative.



- 1.3.8 Stair lifts travel up the pitch of a stair and can either be in the form of a platform or a chair. Where it may be impractical to provide a passenger lift or a platform lift, a stairlift may constitute a reasonable alternative.

A stairlift that incorporates a chair rather than a platform is not considered as a reasonable means of providing Access for All in a building open to the public.



- 1.3.9 Persons with disability should be able to summon and control the lift (including stair lifts) as well as reach any emergency communications device.

See guidelines on Control Systems



- 1.3.10 For a building with two or more stairways between storeys, a stairlift should only be installed on a stairway that is not intended to be used as a means of escape.



Reception Areas

- 1.3.11 The reception point should be in sight of the entrance and easily identifiable by visually impaired people.



- 1.3.12 Counters should be accessible to all including persons using a wheelchair.

See guidelines on Counters & Reception Desks



- 1.3.13 The reception point should be located in a position where the ability of a person with hearing impairment to lip read is not impaired, e.g., by the presence of windows or a glazed screen.

See guidelines on Aural Environment



- 1.3.14 Signs and universally accepted symbols or pictogram, indicating toilets, lifts, stairs circulation, routes and other parts of the building should be provided.

See guidelines on Signage



- 1.3.15 Any permanent or temporary control barriers used for waiting and queuing should allow wheelchair users to manoeuvre to the reception point.



Corridors

- 1.3.16 The design of a corridor or passageway should allow persons with disability to find their way easily and unimpeded.

See guidelines on Doors, Lobbies, Ante-Rooms and Corridors

**Lobbies**

- 1.3.17 Lobby dimensions should have dimensions that allow a person with a wheelchair to use it with ease.

See guidelines on Doors, Lobbies, Ante-Rooms and Corridors

**Doors**

- 1.3.18 Internal doors shall be wide enough as to allow easy access to all including persons using a wheelchair.

See guidelines on Doors, Lobbies, Ante-Rooms and Corridors

**Sanitary Facilities**

- 1.3.19 All buildings open to the public must have provision for accessible to all sanitary facilities.

See guidelines on Sanitary Facilities / Changing Rooms



- 1.3.20 Persons with disability should be able to find and use suitable lavatory accommodation no less easily than non-disabled persons. The space requirements for suitable lavatory accommodation are generally driven by the needs of wheelchair users, although it is recognised that people with other disabilities may also use the facilities, such as visually impaired persons.

**Floor and Surfaces**

- 1.3.21 The extent to which floor, wall, door and ceiling surfaces enable disabled people to find their bearings and maintain their independent use of a building, is influenced by:

- the colour, luminance and texture of the surfaces;
- the treatment of components and finishing elements, such as doors, architraves, skirtings, cornices, handrails, etc. which define, or are contained within, these surfaces;
- the correct use of surfaces to clarify location and direction and to identify objects;
- the grip of floor surfaces, particularly at changes of level;
- treatment of floors and other surfaces to help reception of audio signals by hearing aid users.

See guidelines on Surfaces

See guidelines on Lighting

See guidelines on Aural Environment

See guidelines on Signage

See guidelines on Handrails and Grab rails



Public Telephones, Control Systems and Other Devices

- | | |
|--|-------------------------------------|
| <p>1.3.22 Switches and controls should be accessible and easy to operate for those with different needs.</p> <p style="text-align: right;"><i>See guidelines on Control Systems</i></p> | <input type="checkbox"/> |
| <p>1.3.23 In buildings in which telephones for public use are provided, at least one telephone accessible to hearing impaired persons and one mounted at a height suitable for use by a wheelchair user should be provided in an accessible location in the entrance space. The same holds for other coin or card operated devices.</p> <p style="text-align: right;"><i>See guidelines on Control Systems</i></p> | <input type="checkbox"/> |
| <p>1.3.24 An accessible telephone should include a fold down seat (450mm - 520mm high) or a perch seat (650mm - 800mm high) should be provided for the convenience of ambulant people.</p> | <input type="checkbox"/> |
| <p>1.3.25 The location of devices such as telephone booths, ticket dispensers etc. should not become an obstacle or a safety hazard to persons using a wheelchair or who has a visual impairment.</p> | <input type="checkbox"/> |
| <p>1.3.26 The location of coin and card operated devices (including public telephones) as well as all other control systems should be clearly sign-posted and easily identifiable.</p> <p style="text-align: right;"><i>See guidelines on Signage</i></p> | <input type="checkbox"/> |
| <p>1.3.27 Card and coin operated devices should be located in areas that are not overlooked by people and well lit at all times.</p> | <input type="checkbox"/> |
| <p>1.3.28 Display screens should be carefully shielded from ambient lighting, including sunlight, to prevent glare and reflection, thus ensuring a sharp image is visible by both standing and seated users.</p> | <input type="checkbox"/> |
| <p>1.3.29 Signs should be located above coin and card operated devices and be visible from the side as well as the front. Signs over coin and card operated devices should have integral illumination that is activated at night.</p> | <input type="checkbox"/> |
| <p>1.3.30 The area immediately in front of coin and card operated devices, including privacy areas, should be level and unobstructed and large enough for a wheelchair to manoeuvre, and should as a minimum accommodate a turning circle of 1500mm.</p> <p style="text-align: right;"><i>See guidelines on Control Systems</i></p> | <input checked="" type="checkbox"/> |
| <p>1.3.31 Instructions for using coin or card operated devices should have a clear, large typeface. Text should be clear and easy to understand. Universally recognized pictograms should be used, as well as text.</p> <p style="text-align: right;"><i>See guidelines on Signage</i></p> | <input type="checkbox"/> |

Windows

1.3.32 Height of window sills should be no higher than 800mm above the finished floor level.

1.3.33 The position of window controls should be between 900mm – 1200mm above finished floor level.

See guidelines on Control Systems

1.3.34 The torque force required to operate a lever handle of a window should not exceed:

- 8 Nm to depress and 5.5 Nm to lift a handle with an oval cross section;
- 4 Nm to both depress and lift a handle with a rectangular cross section.

1.3.35 Window furniture needs to be easy to find, reach and use by people who have sight, movement and dexterity impairments.

1.3.36 Window controls should be designed so that someone with a clenched fist can operate them. They should not require the simultaneous use of both hands, as a person may need to use the other hand for support and balance.

1.3.37 Horizontal sliding windows should be capable of being opened and shut using limited force.

Lighting Environment

1.3.38 Lighting levels should be adequate to allow persons with impaired vision to navigate safely within the internal environment.

1.3.39 Sufficient lighting levels are required in areas where lip/sign reading may be required. Lighting should be designed to illuminate the person to make it easier when lip/sign reading.

1.3.40 Lighting should be designed so as not to cause glare and to provide a uniformly lit environment.

See guidelines on Lightning

Aural Environment

1.3.41 Aural levels should be adequate to allow persons with impaired hearing (with the necessary technical support) to reasonably participate fully in the proceedings.

See guidelines on Aural Environment

[P A R T I I] Design Guidelines

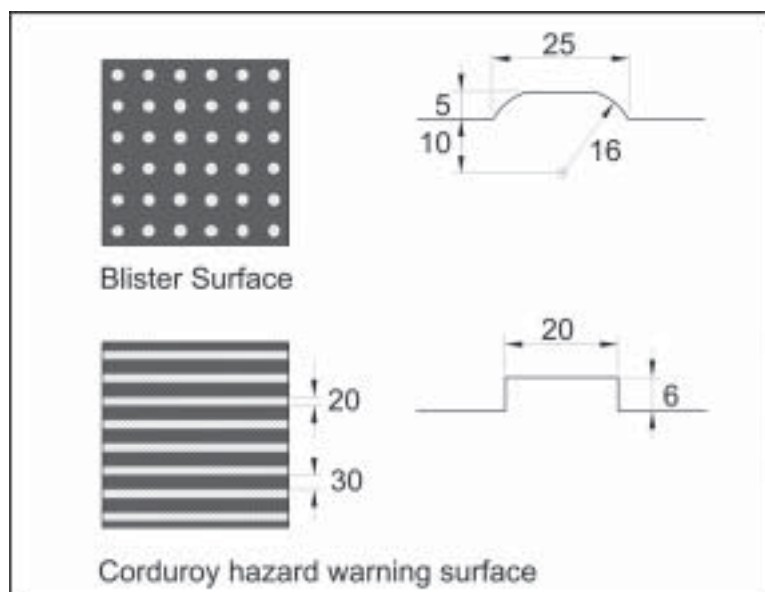
2.1 Surfaces Guidelines

- 2.1.1 An access route should have a firm, slip resistant and reasonably smooth surface. Cobbles, soil, sand and loose gravel should not be used. Where paving is used, the joint between paving units should be flush and level.
- 2.1.2 The material used for outdoor areas and pavements should be such that they provide a smooth and level surface. Asphalt (drainage asphalt on pavement provides effective drainage) is a suitable material. Prefabricated concrete products such as paving slabs and paving blocks are also suitable. Hewn stone or other materials with many gaps are unsuitable as paving materials. Gravel and loose material is also considered unsuitable.
- 2.1.3 Tactile paving should be used on access routes to provide warning and guidance to blind and partially sighted people.
- 2.1.4 The use of tactile surfaces should be used to alert a person with disability, particularly persons with visual impairment of potential hazards. Blister (dome type) tactile surface is to be used to signal that one should stop and ascertain it is safe to proceed; corduroy type tactile surface should be used to signal that a flight of steps lies ahead. (Figure 1)

Items
assessed
at design
drawing stage

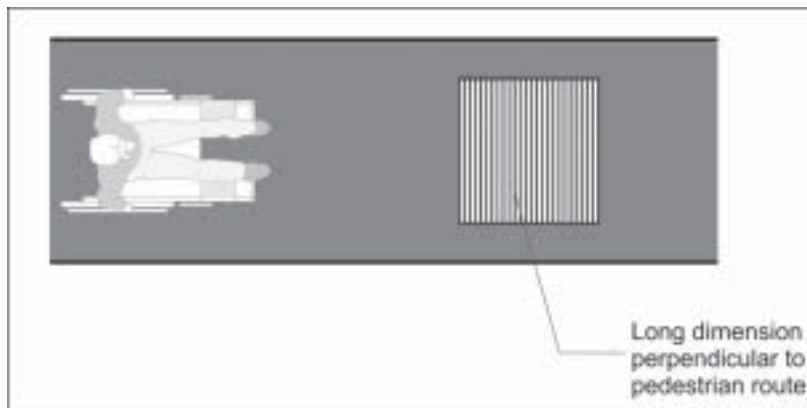


Figure 1: Details of tactile paving



- 2.1.5 Drainage gratings should be positioned beyond the boundaries of the access route. Gratings within an access route should be set flush with the surrounding surface.
- 2.1.6 Slots in gratings should be not more than 13mm wide and set at right angles to the dominant line of travel (Figure 2). The diameter of circular holes in gratings should be not more than 18mm.

Figure 2: Layout of gratings



- 2.1.7 All building flooring and ground surfaces upon which pedestrians are likely to come into contact with shall be designed, specified and constructed so as to reduce the risk of slipping.
- 2.1.8 Polished floors are only acceptable in areas where water or materials giving a similar effect are not likely to be spilled or splashed.
- 2.1.9 All floors, ramps and stairways in or associated with buildings are to be designed, specified and constructed to protect pedestrians from significant drops in level.
- 2.1.10 All flooring surfaces are to be firm, regular, and provide an indication of significant hazards or changes in levels.
- 2.1.11 Floor surfaces should be flush at intersections with particular attention paid to the installation of grates and mats.
- 2.1.12 The use of deep pile, open texture, soft mats or unsecured carpets that impede movement of wheelchair users and ambulant disabled persons are to be avoided.
- 2.1.13 People with visual impairment may have difficulty finding their way around spaces if they cannot respond to visual cues. Luminance contrast is more important than colour contrast in helping visually impaired people distinguish between different surfaces.

2.1.14 Table 1 contains guidance on the potential for slip on dry / unpolished and wet surfaces.



Table 1: Potential for slip of surfaces

Material	Potential for slip		Remarks
	Dry	Wet and polished	
Carpet	Very low	Low	Loose or worn carpet can present a trip hazard.
Cast iron	Low	Moderate to low	Wet slip resistance is dependent on surface roughness. An Rz (din) value of greater than 10 μm is recommended for use in clean water wet areas.
Ceramic tiles (glazed & polished)	Low	High	
Ceramics (profiled)	Low	Moderate to low	Profiled ceramics are suitable for use in barefoot areas. In shod situations, the comment formatt ceramic tiles applies.
Clay tiles	Low	Moderate to low	When surface is wet and polished, the potential for slip can be very high.
Concrete	Low	Moderate to low	If textured finish or a non-slip aggregate is used, potential for slip can be low.
Linoleum	Low	Moderate to low	Edges of sheet liable to cause tripping if not firmly fixed to base.
Mastic asphalt	Low	Low	
PVC	Low	High to moderate	Ex-factory classes for PVC should be treated with caution. The installed floor is unlikely to be suitable for use in wet conditions.
PVC, enhanced slip resistance	Low	Low	The anti-slip properties depend upon sufficient, uniformly distributed aggregate. Areas of reduced aggregate can present a serious slip hazard.
Resin, smooth self levelling	Low	High to moderate	
Resin, enhanced slip resistance	Extremely low	Low	The anti-slip properties depend upon sufficient, uniformly distributed aggregate. Areas of reduced aggregate can present a serious slip hazard.
Rubber	Extremely low	High	Not suitable near entrance doors or other foreseeable wet areas.
Stainless steel	Low	High	Wet slip potential is highly dependent on surface finish. Quoted values for 0.5 μm Rz (din) surface roughness.
Steel profiled (diamond plate)	-	Moderate	Class determined by DIN ramp method. No dry value determined.
Terrazzo	Low	High to moderate	Slip resistant inserts are necessary whenever terrazzo is used for stair treads. Polished terrazzo (including resin based) should not be used for stair treads.
Timber (finished)	Extremely low	High	Applies to sealed or varnished or polished timber.
Timber (unfinished)	Low	Moderate	

2.2 Pavements and Pedestrian Crossings Guidelines

Items
assessed
at design
drawing stage

- | | |
|--|-------------------------------------|
| 2.2.1 The width of a pavement is to be no less than 1200mm. | <input checked="" type="checkbox"/> |
| 2.2.2 The height of the kerbstone is to be no more than 150mm above road level. | <input type="checkbox"/> |
| 2.2.3 Transverse gradients should be level or up to a maximum slope of 1:50.
<i>See guidelines on Ramps</i> | <input type="checkbox"/> |
| 2.2.4 Pavements should be free from both permanent and temporary obstacles. Where occasional obstacles are unavoidable the unencumbered width of the pavement should be no less than 1000mm at any point along its length. | <input type="checkbox"/> |
| 2.2.5 Pavement design should contain physical guide features such as: railings, kerbstones, contrasting colours or tactile material. | <input type="checkbox"/> |
| 2.2.6 Dropped kerbs should be provided at all pedestrian crossing points and where level access is required between the pavement and carriageway (e.g., in a car park, zebra crossings, etc) and at the end of each pavement. | <input checked="" type="checkbox"/> |
| 2.2.7 Drop kerbs should satisfy the following requirements: <ul style="list-style-type: none"> • Slope 1:10 maximum • Kerbs to drop flush with road surface. • 1200mm minimum width • Be complemented by a dropped kerb on the other side of the road and aligned to each other. | <input checked="" type="checkbox"/> |
| 2.2.8 Resting facilities (e.g. benches) should be provided at intervals of at least 50m. | <input checked="" type="checkbox"/> |
| 2.2.9 The bench seat height is to be 500mm above ground level and the arm rests 700mm. | <input type="checkbox"/> |
| 2.2.10 The minimum height of overhanging vegetation shall be no less than 2m from the ground. | <input type="checkbox"/> |
| 2.2.11 The pedestrian crossing is a complicated place and has to satisfy many different needs. In particular, it must satisfy the needs of persons using wheelchairs and visually impaired. Pedestrian crossings should be well illuminated with well-defined and maintained road markings. | <input type="checkbox"/> |
| 2.2.12 Pelican lights should have an audible signal. | <input type="checkbox"/> |
| 2.2.13 Pedestrian crossings should have contrasting markings on the road similar to zebra crossings. | <input type="checkbox"/> |

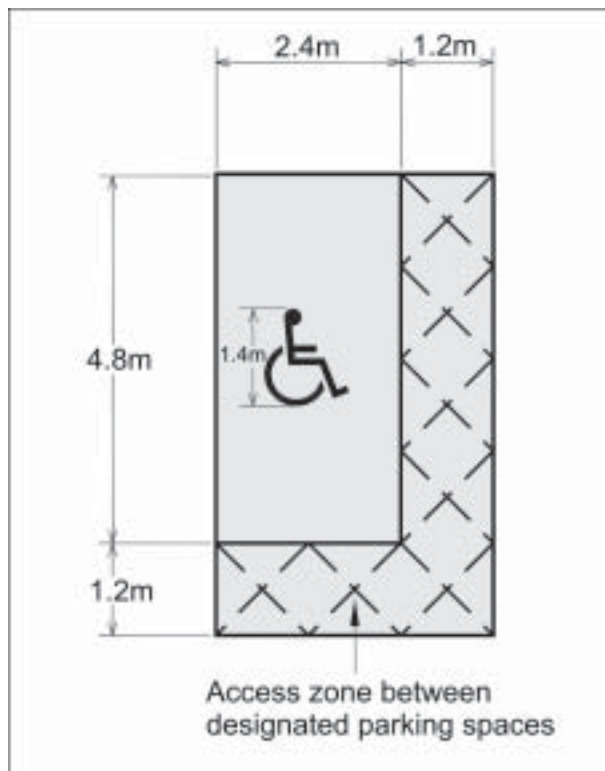
- 2.2.14 At uncontrolled crossings, the tactile surface should be buff or any other colour (except red) that provides a contrast with the surrounding ground surface.
- 2.2.15 At controlled crossings the tactile surface should be red signifying that the pedestrian might signal traffic to stop (e.g., pelican crossing).
- 2.2.16 Tactile paving tiles should extend the whole width of the pavement, so that a person travelling along the pavement will have tactile signal of the crossing. Tactile paving should be at least 1200mm wide in the direction of travel.
- 2.2.17 Where the back edge is not parallel to the kerb, and as a result the depth of the tactile surface varies, it should be no less than 800mm at any point.
- 2.2.18 Crossings at side roads should be inset into the side road approximately 1000mm beyond the radius kerb at corners. The raised radius kerb provides positive guidance for drivers.
- 2.2.19 Dropping the radius section of the kerb (i.e. at the corner) will create difficulties for persons with disability and should be avoided.
- 2.2.20 The surface of traffic islands forming part of a pedestrian crossing in the middle of the road should be all level with the carriageway.

2.3 Parking Guidelines

- 2.3.1 A parking space designated as one for persons with disability shall have a minimum width of 3.6m and a minimum length of 4.8m for perpendicular parking and a minimum length of 6.6m for parallel parking. (Figure 3).



Figure 3: Accessible for All parking space dimensions



- 2.3.2 Table 2 indicates the number of parking spaces suitable for disabled persons required in terms of accessible spaces per total number of parking spaces for visitors.
- 2.3.3 Designated parking spaces should be located on firm and level ground, as close as is reasonable to the principal accessible entrance to the building with which the parking spaces are associated but no further than 50m away from the entrance to the building.
- 2.3.4 Space should be made available to enable a disabled motorist or passenger to alight from a car and then to manoeuvre around parked vehicles as indicated in Figure 4.
- 2.3.5 When there is parking available to the public or workers, such as public or commercial buildings, a number of spaces need to be designated for disabled motorists, whether they are visitors or permanent staff members.
- 2.3.6 Pre-payment machines should be positioned as close as possible to the designated parking space/s.



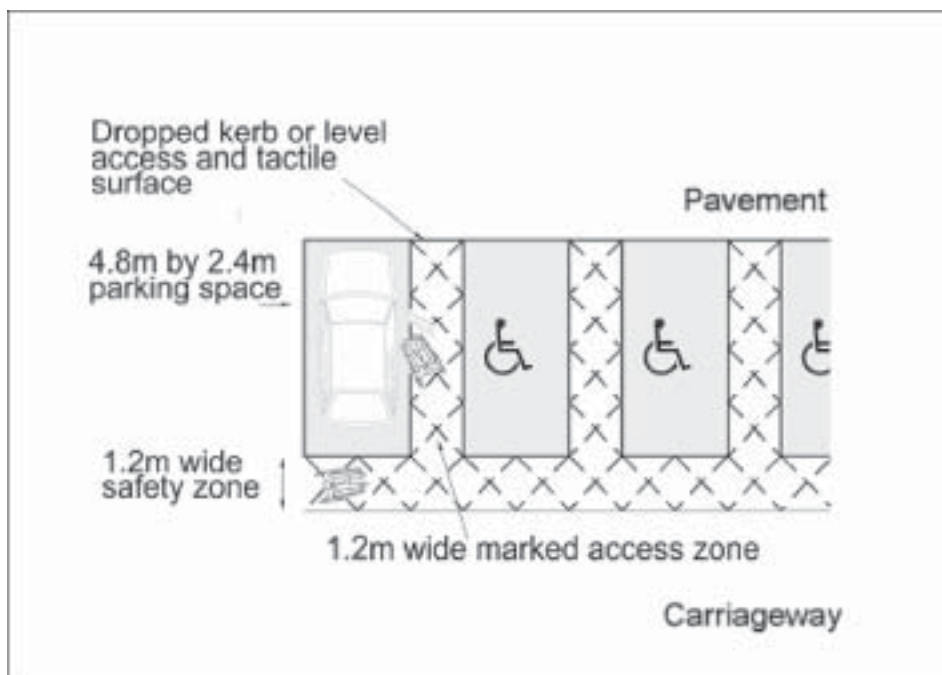
Table 2: Accessible for All parking spaces requirements

Total number of parking spaces	Number of accessible of spaces required
3 – 10	1 space*
11 - 25	2 spaces or 1 van accessible space**
26 – 50	2 including 1 van accessible space
51 – 75	3 including 1 van accessible space
76-100	4 including 1 van accessible space
101-150	5 including 1 van accessible space
151-200	6 including 1 van accessible space
201-300	7 including 1 van accessible space
301-400	8 including 1 van accessible space
401-500	9 including 2 van accessible spaces
501-1000	2% including 3 van accessible spaces
More than 1000	20 + 1 per 100 or fraction, including minimum 1 van accessible space per 8 accessible spaces or fraction thereof

* A space refers to the dimensions indicated in paragraph 2.3.1

** A van accessible space should be minimum 7300mm long and 2900mm wide with 2300mm headroom.

Figure 4: Parking layout for persons with disability



- 2.3.7 The height of ticket, swipe-card or key activated systems for car park barriers should be accessible to all.

See guidelines on Control Systems



- 2.3.8 The space in front of a meter or a ticket dispenser associated with designated parking spaces should be level, free from obstruction and should accommodate a turning circle of 1500mm.

See guidelines on Control Systems



2.4 Ramps Guidelines

- 2.4.1 Gradients of ramps shall be no steeper than the values indicated in Table 3 for the relevant difference in level between the top and bottom of the ramp.

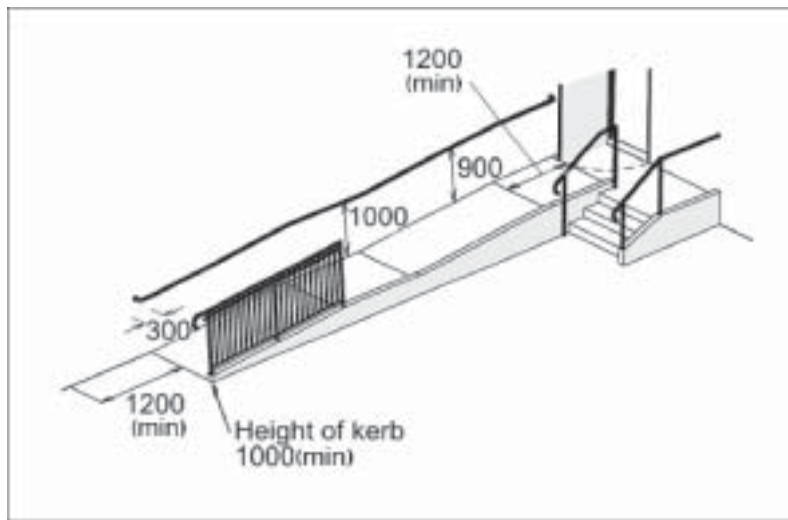
For differences in height between 250mm and 500mm, it is acceptable to interpolate the maximum permissible gradients.

Table 3: Maximum permissible gradients

Vertical Height of Ramp	Maximum permissible gradient
Less than 100mm	1:10
Less than 250mm	1:12
Less than 500mm	1:16
Greater than 500mm	1:20

- 2.4.2 Ramps should be at least 1200mm wide. In all circumstances, the unobstructed width of a ramp must not be less than 1000mm (Figure 5).
- 2.4.3 The width of flights, landings, and ramps is to be measured as the unobstructed width between walls or handrails, whichever is the narrower.
- 2.4.4 The maximum horizontal length of a ramp between level landings is 12m.
- 2.4.5 Ramps shall have landings at the top and bottom, each of whose length shall not be less than 1200mm and, where required, intermediate level landings (Figures 6 and 7).
- 2.4.6 Landings should be no less than 1200mm in length where a straight landing is provided and should accommodate a turning circle of 1500mm where a change in direction, greater or equal to 45 degrees, occurs in the ramp / landing.
- 2.4.7 Unless it is under cover, a landing should have a slight cross fall gradient, not exceeding 1:50.
- 2.4.8 All ramps and landings shall have clear headroom throughout of at least 2m.
- 2.4.9 Ramps shall have a raised kerb at least 100mm high on any open side of a flight or a landing, if no other equivalent protection is provided.
- 2.4.10 All ramps shall be provided with handrails as indicated in the guidelines referring to handrails

See guidelines on Handrails and Grab rails

Figure 5: Details of ramps

- 2.4.11 Ramps shall be constructed of non-slip material. The surface should retain non-slip characteristics even when wet.
- 2.4.12 The colour of the surface of the ramp should contrast in colour with that of the landing so that its presence is distinguishable by people with impaired vision.
- 2.4.13 A ramp should have an adjacent flight of steps to negotiate the difference in levels connected by the ramp.

See guidelines on Stairs

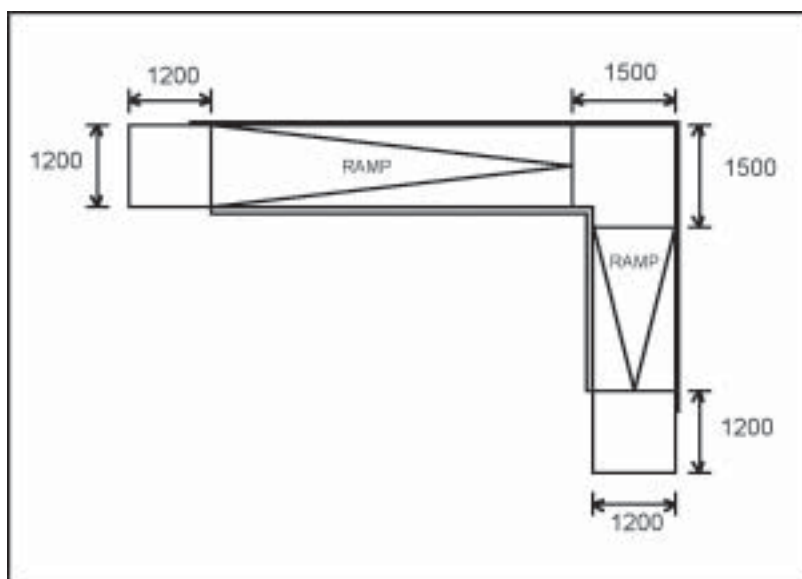
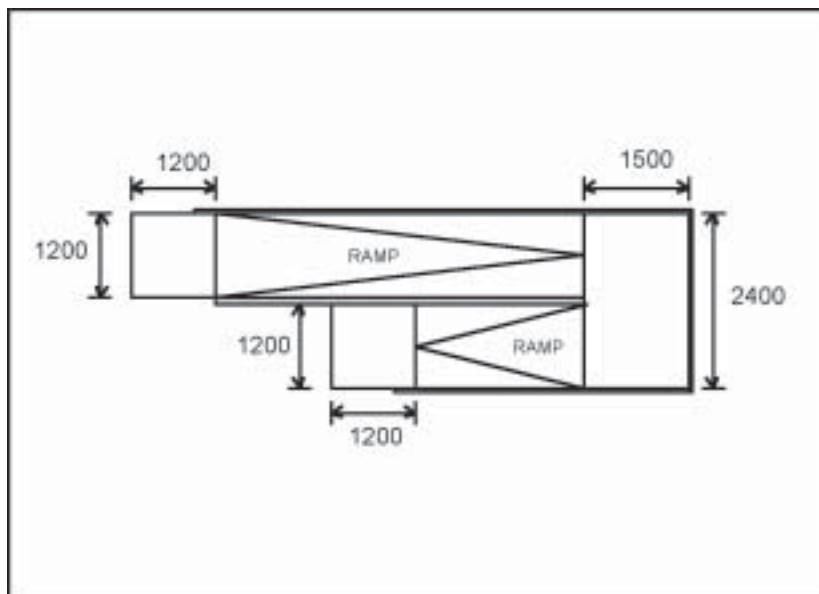
Figure 6: Ramp with 90 degree turn (Minimum dimensions of landings)

Figure 7: Ramp with 180 degree turn (Minimum dimensions of landings)



2.5 Stairs Guidelines

Items
assessed
at design
drawing stage

- | | |
|---|-------------------------------------|
| 2.5.1 Many ambulant disabled persons find it easier to negotiate a flight of steps than a ramp and for them certain features incorporated in the design of stairs will reduce the risk of tripping or falling. | <input type="checkbox"/> |
| 2.5.2 In any flight of stairs, all steps shall have the same rise height and the same going width throughout the entire flight. | <input type="checkbox"/> |
| 2.5.3 The angle of pitch of staircases shall be limited to 38 degrees in common/public stairs. | <input type="checkbox"/> |
| 2.5.4 The rise of each step shall not be greater 170mm. | <input type="checkbox"/> |
| 2.5.5 'Open risers' staircases will only be permitted in public areas where an alternative staircase that has closed risers is provided in reasonable close vicinity to the open-riser staircase. | <input type="checkbox"/> |
| 2.5.6 The number of risers in between landings in a flight shall be limited to a maximum of 12 risers in a stairway in a public building or an outdoor area. | <input checked="" type="checkbox"/> |
| 2.5.7 All stairs shall have clear headroom over the length and width of the stairway and its associated landings of at least 2m measured vertically from the line of pitch. | <input type="checkbox"/> |
| 2.5.8 Protruding nosings are not acceptable as they may cause persons with disability to trip. | <input type="checkbox"/> |
| 2.5.9 Flights of steps less than 3m in width shall have handrails on both sides. In addition to this, flights of steps up to 6m in width shall have a handrail in the middle of the flight. Flights greater than 6m in width shall have handrails at intervals of 3m along the width of the flight. | <input checked="" type="checkbox"/> |
| 2.5.10 The minimum width of stairs should be 1000mm provided that any stairs shall have no flight wider than 1200mm unless it is divided by handrails in sections no greater than 1200mm. | <input checked="" type="checkbox"/> |
| 2.5.11 The width of flights and landings is to be measured as the unobstructed width between walls or handrails, whichever is the narrower. | <input type="checkbox"/> |
| 2.5.12 A level landing should be provided at the top and bottom of each flight of steps or stairs. Its length, clear of any door or gate swing, should be at least the stair clear width and in all cases at least 1200mm. Part of the floor of the building may be considered as a landing. | <input checked="" type="checkbox"/> |
| 2.5.13 Landings shall be level or may slope to a maximum gradient of 1:50. | <input type="checkbox"/> |

- 2.5.14 The presence of well-designed handrails is a critical aspect of accessible staircases. A flight of steps that consists of two or more risers shall be provided with a continuous handrail on each side.

See guidelines on Handrails and Grab rails

- 2.5.15 If any stairway or flight of steps consists of two or more flights, separated by a landing or landings, each handrail should be continuous throughout the series of flights.

See guidelines on Handrails and Grab rails

- 2.5.16 Each flight and landing of steps and stairs should be well illuminated, by means of artificial lighting providing a clear distinction between each step and riser. The illuminance at tread level should be a minimum of 100 lux. Lighting that will cause glare (e.g., poorly located spot lights, floodlights or low level light sources) should be avoided.

See guidelines on Lighting

- 2.5.17 People with impaired sight risk tripping or losing their balance if unaware of steps or a flight of stairs. For such people, the provision of tactile warning underfoot is essential.

- 2.5.18 Steps shall have level treads and be slip resistant.

- 2.5.19 All landings in flights of steps should be provided with a tactile hazard warning.

See guidelines on Surfaces

- 2.5.20 All landings in flights of steps should contrast in colour and luminance with the treads.

See guidelines on Lighting

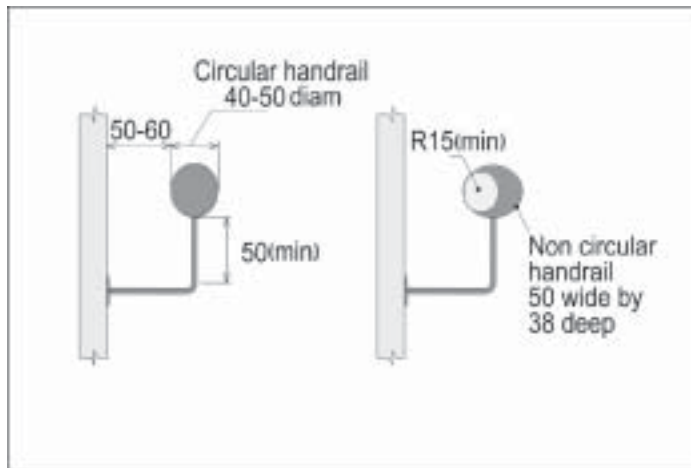
2.6 Handrails / Grab rails Guidelines

Items
assessed
at design
drawing stage

- 2.6.1 Handrails should have a round or oval profile with a minimum outside diameter of 35mm and a maximum outside diameter of 50mm. Oval profile handrails should be 50mm wide and 40mm deep, with rounded edges with a radius of at least 15mm. (Figure 8).

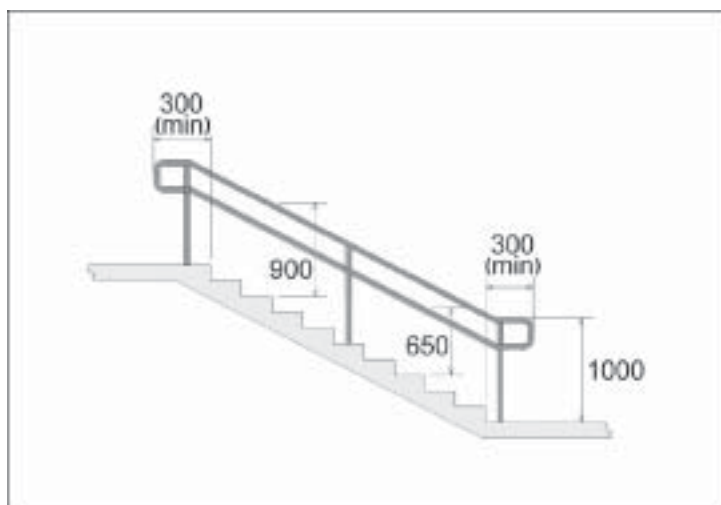


Figure 8: Details of handrails



- 2.6.2 The surface of the handrail should provide a good grip.
- 2.6.3 Metal surfaces which are cold to touch in a cold environment or hot in a hot environment should be avoided. The surface material should have low-heat conductive characteristics (e.g., wood).
- 2.6.4 To avoid impeding finger grip, consideration needs to be given to the spacing of a handrail away from any adjacent wall. The clear distance between the edge of the handrail and the walls should be between 50mm to 60mm.
- 2.6.5 Ramps shall have a handrail on one side only where its width is less than 1500mm and on both sides of the ramp where its width is greater than 1500mm. Provided that ramps that are less than 1000mm in length are not required to have a handrail.
- 2.6.6 Ramps where crowding or heavy volumes of traffic can be anticipated shall additionally have a central handrail where the flight is wider than 3m.
- 2.6.7 Handrails shall extend at least 300mm beyond the top of the ramp and at least 300mm beyond the bottom of the ramp.
- 2.6.8 Handrails shall extend at least 300mm from the first and last nosing, and as much as possible should be horizontal. The extension should not intrude into a circulation route.



Figure 9: Details of handrails flanking steps

- 2.6.9 Handrails should be fixed at a height of 900mm above the ground level of ramps and 1000mm above landings.
- 2.6.10 Where the overall width of a flight of steps is greater than 3m, an additional handrail or handrails should be provided to divide the flight into separate channels.
- 2.6.11 The vertical height to the top of the handrail should be between 900mm and 1000mm from the pitch line of a flight and between 900mm and 1100mm from the surface of the landing (Figure 9).
- 2.6.12 Accessible lifts should be provided with a handrail along one side of the passenger car fitted at a height of 900mm above the car lift floor.

Grab rails

- 2.6.13 Grab rails should be 25 to 32mm in diameter, fixed with a clearance between the rail and the wall of 50mm to 60mm, and with a good grip when wet.
- 2.6.14 In accessible toilets, the WC compartment should have horizontal support rails that shall be positioned at no more than 500mm from the centre line of the WC, on both sides of the WC, at least, one being a hinged support rail to permit access and support.
- 2.6.15 The height of the support rails in the WC compartment is to be 250mm above the height of the WC seat.
- 2.6.16 The WC compartment should have 600mm long vertical support rail is to be fixed on the free side of the WC, 800mm from the floor, and a second is to be fixed at the same height and immediately to the side of the wash hand basin.

2.6.17 Dressing cubicles / changing rooms shall be provided with a horizontal grab rail 700mm from the floor at the side of the seat.

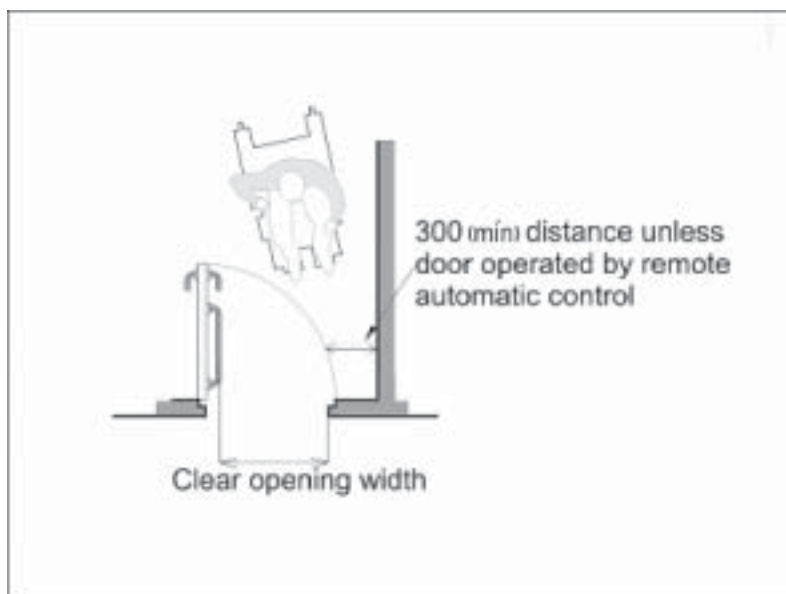
2.6.18 Shower cubicles shall be provided with grab rails as follows:

- Horizontal grab rail 700mm from the floor at the side of the seat.
- Vertical grab rail from 900mm to 1400mm from the floor.

2.7 Doors, Lobbies, Ante-Rooms and Corridors Guidelines

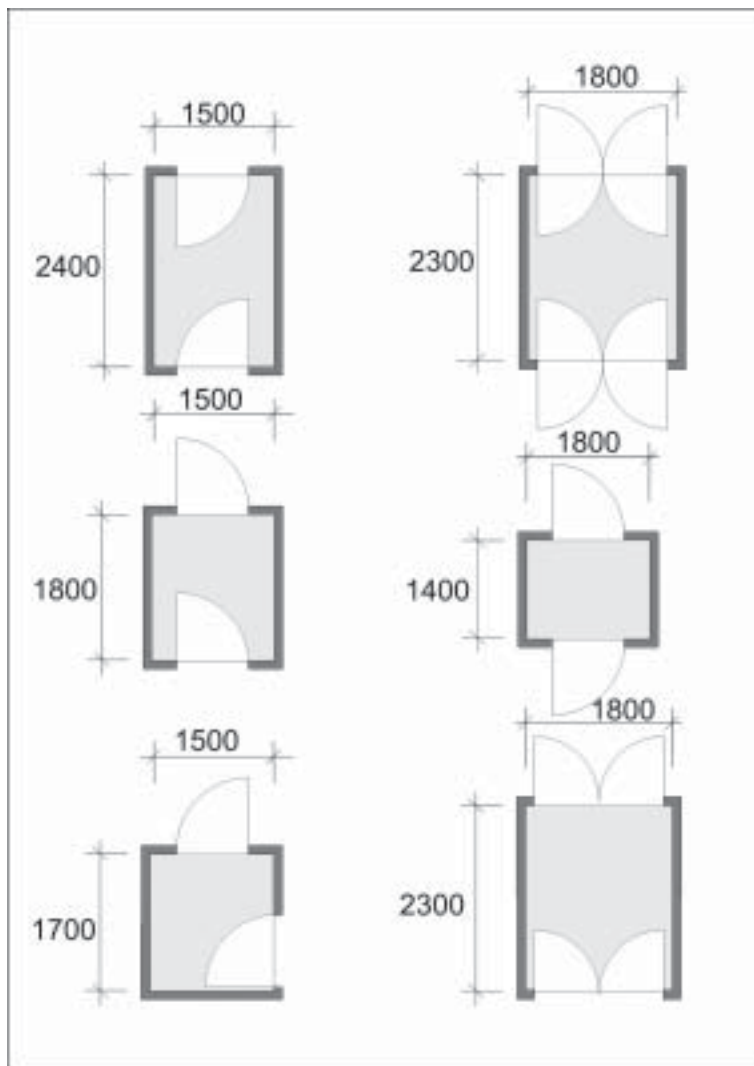
Items
assessed
at design
drawing stage

- | | |
|--|-------------------------------------|
| <p>2.7.1 The principal main accessible entrance door should have a minimum clear opening width of not less than 900mm. Principal main entrances should be fitted with automatic doors.</p> | <input checked="" type="checkbox"/> |
| <p>2.7.2 Door thresholds should be level and flush with the surrounding floor. Where this is reasonably unavoidable, the tolerated change in level is no more than 15mm and the threshold should be chamfered at the edges.</p> | <input checked="" type="checkbox"/> |
| <p>2.7.3 The door should permit an unobstructed space on the side next to the leading edge of the door of at least 300mm unless the door is controlled by a suitable automatic control (Figure 10).</p> | <input checked="" type="checkbox"/> |
| <p>2.7.4 Internal doors should be provided with a glazed panel giving a zone of visibility from a height of 900mm to 1500mm from the finished floor level wherever the opening action of the door could constitute a hazard.</p> | <input type="checkbox"/> |
| <p>2.7.5 The entrance door should contrast in luminance with its immediate surroundings and should be well lit and clearly signed.</p> | <input type="checkbox"/> |
| <p>2.7.6 Internal doors should have a leaf that provides a minimum clear opening width of not less than 850mm (except lift doors that should have an opening width of not less than 900mm).</p> | <input checked="" type="checkbox"/> |
| <p>2.7.7 Lever handles should be used, where relevant, in conjunction with an upright mortise lock / latch. Unobstructed access to the handle/keyway should be provided. The cylinder should either be above the lever handle or the minimum distance between the handle and the keyway of the locking system should be 75mm high. Other door ironmongery should be similarly suitable to persons with disability.</p> | <input type="checkbox"/> |
| <p>2.7.8 The location of door opening fittings should be consistent throughout a property.</p> | <input type="checkbox"/> |
| <p>2.7.9 All door furniture should contrast in colour and luminance with the surface of the door.</p> | <input type="checkbox"/> |
| <p>2.7.10 Doors should be easily distinguishable from the adjoining wall by colour and luminance contrast.</p> | <input type="checkbox"/> |
| <p>2.7.11 Where doors are fitted with self-closing mechanisms, the maximum closing force at the leading edge of a door fitted with this device should not exceed 20 Newtons.</p> | <input type="checkbox"/> |

Figure 10: Clear opening width of door

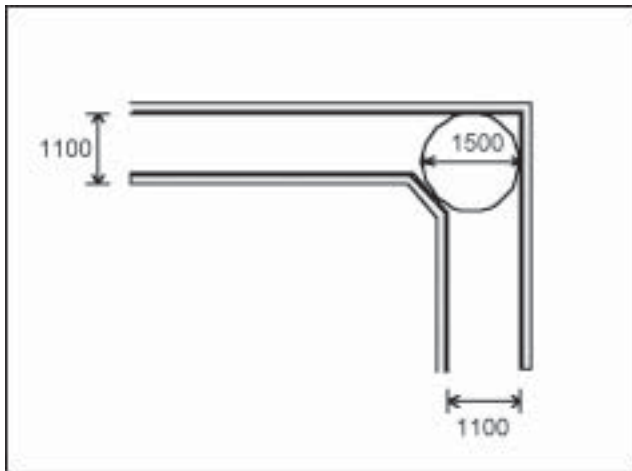
- 2.7.12 Where doors are required to be bolted, one of the following systems should be employed:
- Slide flush or surface bolts with a free moving slide action.
 - Rack and pinion mortise bolts fitted with fixed knobs to enable the user to operate them easily.
 - A surface mounted or mortised espagnolette bolt with top and bottom shoots or side shoots operated by a single handle positioned at a height between 750mm and 1000mm from the finished floor level.
- 2.7.13 The presence of a glass door should be made apparent, with permanent strips on the glass (manifestation) within a zone 1400mm to 1600mm from the floor, contrasting in colour and luminance with the background seen through the glass in all light conditions. The edge of the glass door should also be apparent when the door is open.
- 2.7.14 Where applicable, doors should be clearly marked to indicate whether the door is to be pushed or pulled to open.
- See guidelines on Signage*
- 2.7.15 Emergency exits should be designed to provide emergency egress for persons with disability particularly wheelchair users.
- 2.7.16 Bathroom / WC doors should open outwards unless the depth of the room is more than 2.2m.
- 2.7.18 Bathroom / WC doors should be fitted with a horizontal pull rail.
- 2.7.19 Minimum dimensions of lobbies should be as indicated in Figure 11. Lobby dimensions should be clear of any elements that project into the lobby. Unisex toilets are not required to have an ante-room.



Figure 11: Minimum dimensions of lobbies

- 2.7.20 The design of a corridor or passageway should allow persons with disability to find their way easily and unimpeded.
- 2.7.21 Corridors and passageways shall have a clear width of at least 1100mm for corridors of length up to 15m and a minimum width of 1500mm for lengths over 15m.
- 2.7.22 Corridors must have sufficient space at corners to accommodate the turning movement of a wheelchair as set out in Figure 12.
- 2.7.23 Projections into the circulation routes should be avoided. Wherever this is unreasonable, hazard protection should be provide if objects project more than 100mm into an access route and their lower edge is more than 300mm above the ground. Hazard protection should take the form of a kerb or other solid barrier so that a blind or partially sighted person can detect the hazard using a cane.

Figure 12: Width of corridor and required turning circle



- 2.7.24 Any door that opens towards a frequently used corridor should be located in a recess at least as deep as the width of the door leaf.
- 2.7.25 Doors and apertures with large expanses of glass or similar transparent material are required to have adequate manifestation.

2.8 Lifts Guidelines¹

Items
assessed
at design
drawing stage

- | | | |
|--------|---|-------------------------------------|
| 2.8.1 | Lifts are an essential amenity for disabled people in multi-storey buildings. Lifts may be passenger lifts, platform lifts or stair lifts. | <input type="checkbox"/> |
| 2.8.2 | Platform lifts transfer persons on a guarded platform vertically from one level to another. Where it may be impractical to provide a passenger lift, a platform lift may constitute a reasonable alternative. | <input type="checkbox"/> |
| 2.8.3 | Stair lifts travel up the pitch of a stair and only those in the form of a platform are acceptable. A stairlift that incorporates a chair rather than a platform is not considered as an acceptable means of providing Access for All in a building open to the public. | <input checked="" type="checkbox"/> |
| 2.8.4 | Multi storey buildings should have at least one lift that is of sufficient size to be accessible by wheelchair users and should serve all floors. | <input checked="" type="checkbox"/> |
| 2.8.5 | The distance between Access for All lifts and the extremity of the floor it serves shall be no greater than 40m. | <input checked="" type="checkbox"/> |
| 2.8.6 | The minimum internal dimensions of the cabin of the passenger lift in a new building should be 1100mm wide and 1400mm deep. Hence the lift shaft should be large enough to accommodate such a cabin (Figure 13). | <input checked="" type="checkbox"/> |
| 2.8.7 | In an existing building, internal dimensions of the cabin of the passenger lift 1000mm wide and 1250mm deep may be considered acceptable in those instances where the larger lift size mentioned in the foregoing cannot be accommodated. | <input checked="" type="checkbox"/> |
| 2.8.8 | Lifts shall have a clear landing which accommodates a turning circle of 1500mm in front of the lift doors. | <input checked="" type="checkbox"/> |
| 2.8.9 | Lift door, or doors, shall have a clear opening width of at least 900mm.
<i>See guidelines on Doors</i> | <input checked="" type="checkbox"/> |
| 2.8.10 | Lifts shall incorporate a signalling system that gives 5 seconds notification that the lift is answering a call, and a dwell time of 5 seconds, before its doors begin to close after they are fully open. The system may be overridden by a door reactivating device provided that the minimum time for a lift door to remain fully open is 5 seconds. | <input type="checkbox"/> |
| 2.8.11 | A lift door should be easily distinguishable from the adjoining wall by colour and luminance contrast. | <input type="checkbox"/> |

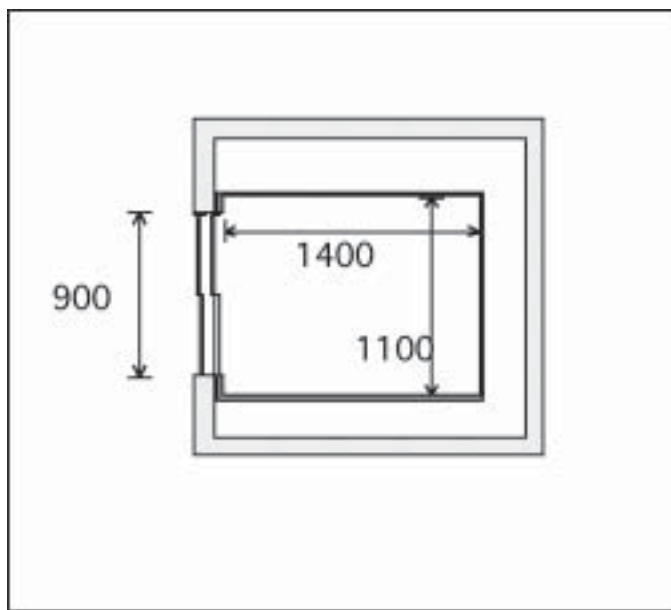
¹ Lifts must satisfy Health and Safety requirements as stated in MSA EN 81-70:2003 and MSA ISO 9368-1:2005.

2.8.12 Persons with disability should be able to summon and control the lift as well as reach any emergency communications device.

2.8.13 The centre line of the highest button of the landing and car controls should be between 900mm and 1100mm above the landing or the car floor, and the car controls are to be at least 400mm from the front wall of the car.

See guidelines on Control Systems

Figure 13: Internal lift car dimensions of an accessible to all lift



2.8.14 Call buttons should contrast in colour and luminance with the surrounding faceplate, and the faceplate should similarly contrast with the wall on which it is mounted.

2.8.15 Lifts shall incorporate a suitable tactile indication on, or adjacent to, the lift buttons within the car to confirm the floor selected.

2.8.16 All lifts serving more than two floors shall have an auditory and visual signal to indicate the floor level the lift has reached.

2.8.17 Passenger lifts should be fitted with an emergency communication system that should incorporate an induction coupler for the benefit of people who wear hearing aids. A visual indicator should be provided to confirm that an emergency call has been received.

2.8.18 The floor of the lift car should be slip resistant and have similar frictional qualities to the floor of the lift landing to decrease the risk of stumbling.

See guidelines on Surfaces

2.8.19 The minimum clear dimensions of a platform lift should be 1050mm wide by 1250mm long.



2.8.20 Platform lifts should be provided with clear instructions for use and fitted with an alarm in case of difficulty.



See guidelines on Signage

2.8.21 Platform lifts are acceptable with a vertical travel distance up to 2m in a public building without a lift enclosure or up to 4m where there is a lift enclosure.



2.8.22 Where a platform lift is installed, a stair access conforming to the relevant standard in these guidelines shall be provided to complement the platform lift.



2.9 Sanitary Facilities / Changing Rooms Guidelines

Items
assessed
at design
drawing stage

- | | |
|--|-------------------------------------|
| 2.9.1 All public buildings must have provision for accessible to all sanitary facilities. | <input checked="" type="checkbox"/> |
| 2.9.2 Persons with disability should be able to find and use suitable lavatory accommodation no less easily than non-disabled persons. The space requirements for suitable lavatory accommodation are generally driven by the needs of wheelchair users, although it is recognised that people with other disabilities may also use the facilities, such as visually impaired persons. | <input type="checkbox"/> |
| 2.9.3 Sanitary facilities should be made separately from any provision made for male and female sanitary accommodation. Integral provision within the male and female areas of sanitary accommodation is acceptable. | <input checked="" type="checkbox"/> |
| 2.9.4 Access for different sexes should be, at least, on alternate floors if unisex toilets are not provided. | <input type="checkbox"/> |
| 2.9.5 Doors to sanitary facilities and changing rooms should have a 900mm single leaf outward opening door lockable from the inside fitted with a lever handle and horizontal pull rail.
<i>See guidelines on Doors, Lobbies, Ante-Rooms and Corridors</i> | <input checked="" type="checkbox"/> |
| 2.9.6 Travel distances to accessible sanitary accommodation from any point in the building are to be no greater than 40m. | <input checked="" type="checkbox"/> |
| 2.9.7 All accessible sanitary facilities are required to have a number of grab rails.
<i>See guidelines on Handrails and Grab Rails</i> | <input type="checkbox"/> |
| 2.9.8 Sanitary facilities floors should be slip resistant and as level as possible subject to the minimum fall for draining water to a floor drain. | <input type="checkbox"/> |
| 2.9.9 A shelf should be provided for toiletries in a position that can be reached by a wheelchair user before and after transfer and should be located at a height of between 800mm and 1000mm above the finished floor level. | <input type="checkbox"/> |
| 2.9.10 Taps should be lever operated. | <input type="checkbox"/> |
| 2.9.11 A self-locating plug and chain, or a pop-up waste mechanism operated from the mixer tap should be provided, with special consideration for person with restricted hand dexterity. | <input type="checkbox"/> |
| 2.9.12 Hot water and other pipes should be lagged or boxed beneath basins in order to protect those with paralysed limbs. | <input type="checkbox"/> |

- 2.9.13 The WC compartment should have minimum internal dimensions of 2000mm long by 1500mm wide. To be suitable for wheelchair users WC compartments shall have as a minimum, the dimensions, equipment and fittings as set out in Figures 14 and 15. Fittings should be laid out to allow for a 1500mm diameter turning circle within the cubicle. If the door of the cubicle opens inwards the minimum dimensions of the cubicle are 2200mm long by 1500mm wide.
- 2.9.14 The WC compartment should have a WC installed as follows: the front to be 750mm from the wall behind it, the top of the WC 480mm from the finished floor, and the centre line to be no closer to the side wall than 500mm.
- 2.9.15 If a building contains more than one WC compartment for wheelchair users, the opportunity should be taken to provide both left-and right-handed transfer layouts.
- 2.9.16 The WC compartment should have a wash hand basin, the top to be 750mm from the finished floor, and fitted with lever taps.
- 2.9.17 Shallow basins are preferred and should not project into circulation space.
- 2.9.18 Adequate knee-room should be allowed beneath the basin to enable a wheelchair user to reach the taps. Pedestal basins should not be used.
- 2.9.19 Hand basin, toilet paper holder, rails and other fittings should be located close to the toilet bowl at the heights included in Figure 15. A hot air hand drier is preferred to a towel.
- 2.9.20 Dressing cubicles / changing rooms shall have a minimum internal width of 2m and internal length of 2.2m. Fittings should be laid out to allow for a 1500mm diameter turning circle within the cubicle.
- 2.9.21 Dressing cubicles / changing rooms shall be provided with the facilities as follows:
- Horizontal grab rail 700mm from the floor at the side of the seat.
 - A mirror from 550mm to 1450mm above floor level.
 - A zone for switches etc. at between 900mm and 1200mm above floor level.
 - A minimum unobstructed internal height of 2.2m.
-
- 2.9.22 Shower compartments shall be dimensioned and provided with the facilities as shown in Figures 16 and 17.
- 2.9.23 Shower cubicles shall have a minimum internal width of 2m and internal length of 2.2m.

- 2.9.24 Shower cubicles shall be provided with the facilities as follows:
- Horizontal grab rail 700mm from the floor at the side of the seat.
 - Vertical grab rail from 900mm to 1400mm from the floor.
 - A zone for switches, etc. at between 900mm and 1200mm above floor level.
 - The showerhead variable between 1200mm and 1400mm from the floor.
 - A shelf.
- 2.9.25 A tip up plastic shower seat with a slip resistant finish should be provided.
- 2.9.26 A shower fitting should be controlled by a lever operated, thermo static mixer that delivers water at a temperature not exceeding 40 degrees Celsius. The markings on the shower control should be clear to visually impaired persons.
- 2.9.27 A shower curtain operated from a shower seat should enclose the seat and rails when they are in horizontal position.
- 2.9.28 A facility for changing diapers should be provided in buildings which by virtue of their size or layout are required to have 10 or more toilets open to the public, and in buildings which likely to be frequently used by persons with disability.
- 2.9.29 Bathrooms intended for independent use by persons with disability shall have a minimum internal width of 2.5m and internal length of 3.1m. To be considered as accessible to all, a bathroom must include a shower, such that a wheelchair user may use the shower facility without having to transfer off a wheelchair. Fittings should be laid out to allow for a 1500mm diameter turning circle within the bathroom.
- 2.9.30 The bath in an accessible bathroom should have a minimum length of 1600mm and a minimum width of 700mm with a slip resistant, flat base.
- 2.9.31 The bath rim of a bath for independent use should be 480mm above floor level at the transfer end. Any grab rails fitted to the rim should not project above this height.
- 2.9.32 Where space is available, a securely fixed transfer seat the same width as the bath and extending beyond the head of the bath by at least 400mm should be provided for ambulant disabled users and wheelchair users with the top surface set at bath rim height.
- 2.9.33 In the case of irregular configuration of a room containing any of the above sanitary services, access to the specific facilities should allow for a turning circle of 1500mm.
- | |
|-------------------------------------|
| <input type="checkbox"/> |
| <input type="checkbox"/> |
| <input type="checkbox"/> |
| <input type="checkbox"/> |
| <input checked="" type="checkbox"/> |
| <input checked="" type="checkbox"/> |
| <input checked="" type="checkbox"/> |
| <input type="checkbox"/> |
| <input type="checkbox"/> |
| <input checked="" type="checkbox"/> |

Figure 14: Details of accessible to all WC cubicle (plan)

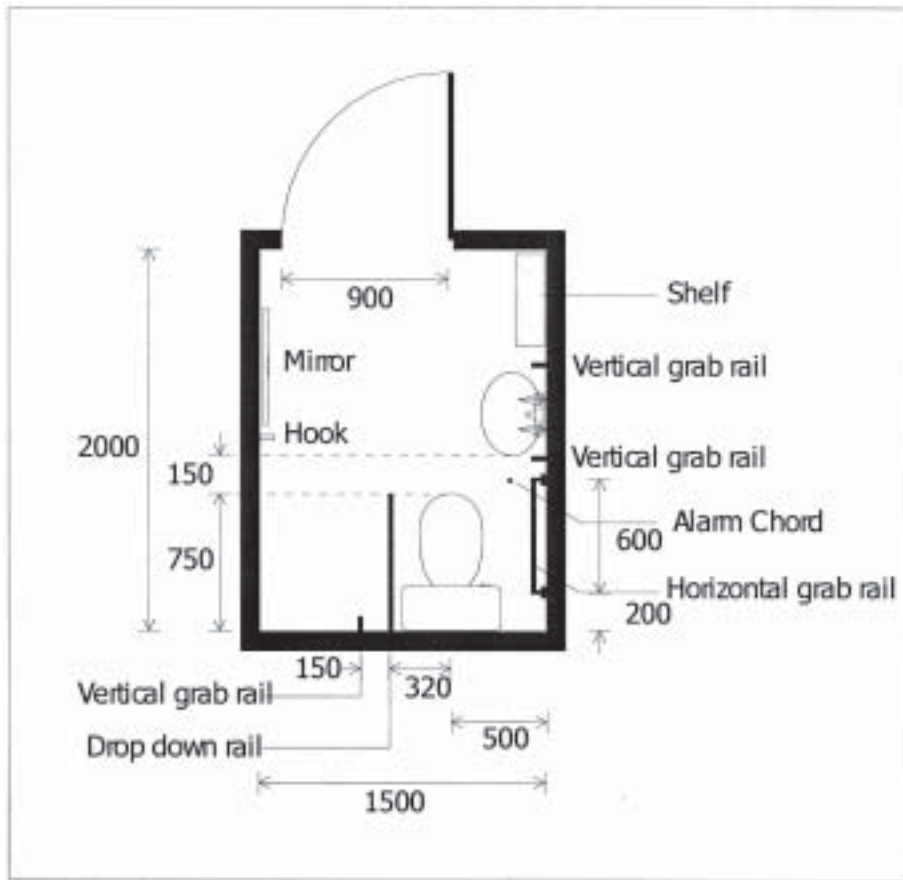


Figure 15: Details of accessible to all WC cubicle (elevation)

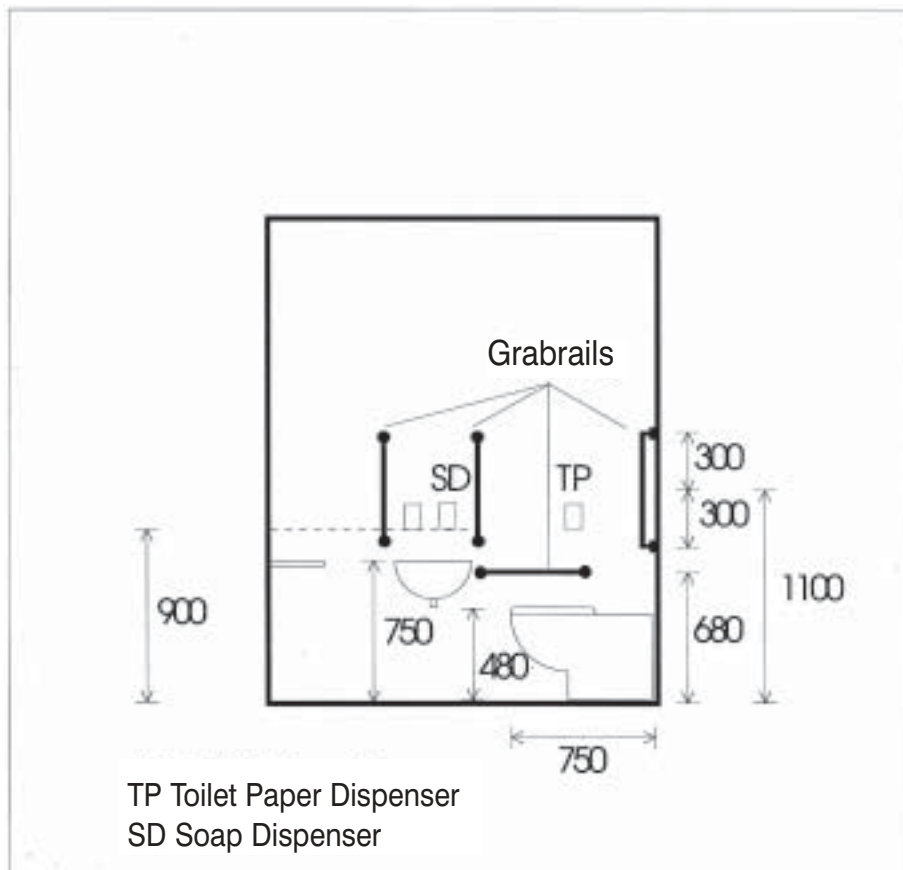


Figure 16: Details of accessible to all shower cubicle (plan)

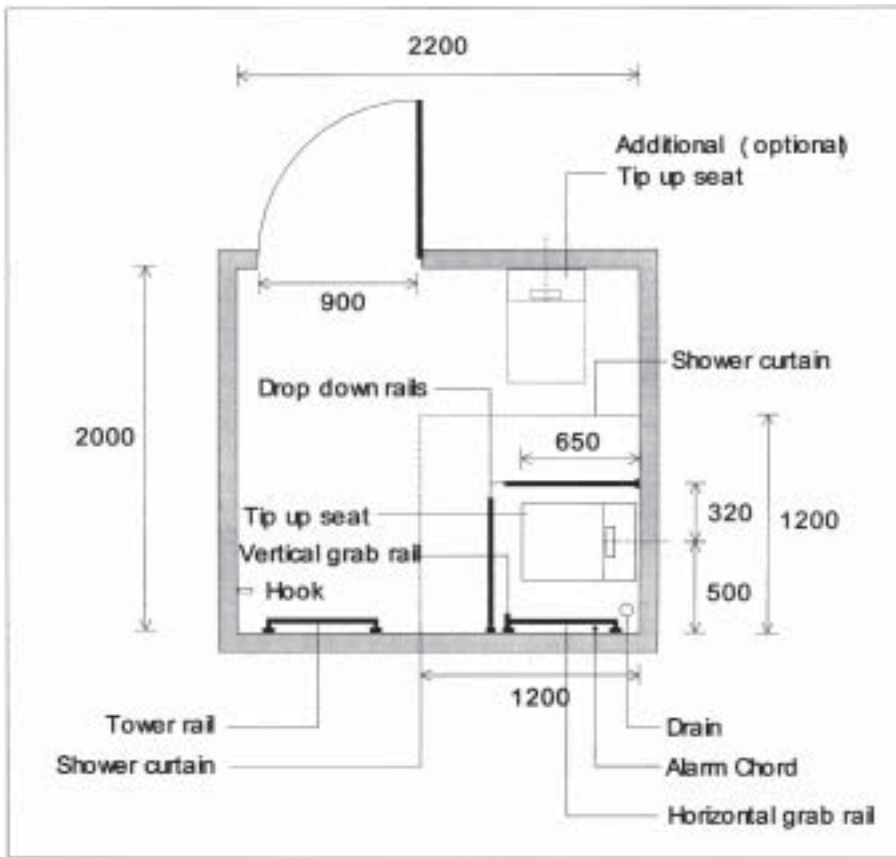
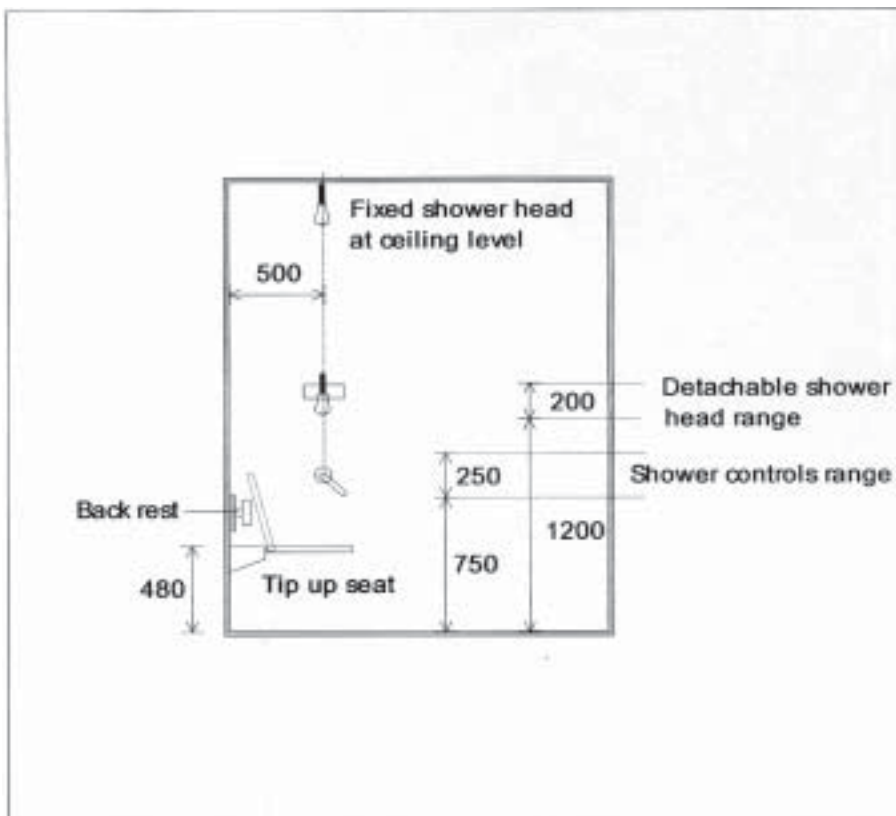


Figure 17: Details of accessible to all shower cubicle (elevation)



2.10 Counters & Reception Desks Guidelines

Items
assessed
at design
drawing stage

- | | | |
|---------|--|--------------------------|
| 2.10.1 | Counters or reception desks should be located so they are easily identifiable from a building entrance. | <input type="checkbox"/> |
| 2.10.2 | Where waiting and queuing is the normal pattern of use, permanent or temporary control barriers should allow wheelchairs to turn towards the counter or desk. | <input type="checkbox"/> |
| 2.10.3 | The clear maneuvering space in front of a counter or reception desk or similar fittings should accommodate a turning circle of 1500mm diameter. | <input type="checkbox"/> |
| 2.10.4 | A reception desk or counter should have a working surface at two heights: <ul style="list-style-type: none"> • between 950mm and 1100mm to accommodate people who are standing; • 760mm to accommodate wheelchair users. | <input type="checkbox"/> |
| 2.10.5 | Two work surface heights should be provided to accommodate customers or visitors standing and sitting (including wheelchair users), as appropriate to the circumstance. The lower level counter (i.e., 760mm above floor) should extend for a distance of at least 1500mm. | <input type="checkbox"/> |
| 2.10.6 | A high seat or stool should be provided so that people with limited standing ability can use both hands for a transaction. | <input type="checkbox"/> |
| 2.10.7 | Where a customer and a receptionist are opposite each other (and one is in a wheelchair), a minimum work surface depth of 700mm should be provided | <input type="checkbox"/> |
| 2.10.8 | Where tickets or coins are involved in transactions, an upward sloping leading edge should be provided at the front of a counter to help people with impaired dexterity to grip coins. | <input type="checkbox"/> |
| 2.10.9 | When a glazed security screen is used above a counter or reception desk, an induction loop system should be provided in addition to standard amplification. It should be clearly indicated with the standard symbol.
<i>See guidelines on Signage</i> | <input type="checkbox"/> |
| 2.10.10 | To facilitate lip reading, lighting design should ensure that a receptionist's face is evenly lit. Security screens should be so designed to ensure reflections are avoided.
<i>See guidelines on Lighting</i> | <input type="checkbox"/> |
| 2.10.11 | A counter or reception desk should be fully accessible to all from both the visitor's and staff's side. | <input type="checkbox"/> |
| 2.10.12 | The clear height from the floor surface to the underside of the counter or its support rail should be at least 700mm at the staff side. | <input type="checkbox"/> |

- 2.10.13 Signs associated with counters and reception desk should be large enough to be read at a distance and placed at a height that is convenient for wheelchair users to read.



See guidelines on Signage

2.11 Control Systems Guidelines

2.11.1 Controls should be positioned as indicated in Table 4.

Table 4: Position of controls

Electrical / light switches	Between 750mm and 1200mm from the finished floor levels
Landing and car controls of lifts	
Controls of ATMs	
Ticket dispensers	
Card operated door entry system	
Card swiping mechanism	
Doorbells	
Window fastenings	
Letterboxes	
Telephone buttons	
Any other mechanism than need to be operated by a wheelchair user.	
Power sockets	Between 400mm and 1000mm above the finished floor level.
TV sockets	
Telephone sockets	

- 2.11.2 Controls should contrast in colour and luminance with the surrounding faceplate and the faceplate should similarly contrast with the wall on which it is mounted.
- 2.11.3 Meters should be mounted between 1200mm and 1400mm from the floor so that the readings can be viewed by a person standing or sitting.
- 2.11.4 Outlets, switches and other controls should be at least 400mm from room corners.
- 2.11.5 Where control systems are located within a panel, such as phones, PC/ internet outlets, and ATMs these should have a knee recess at least 500mm deep and 700mm high and the space in front of the panel should accommodate a turning circle of 1500mm diameter.
- 2.11.6 Card swiping mechanism should be oriented vertically.

2.12 Lighting Guidelines

Items
assessed
at design
drawing stage

- 2.12.1 Lighting levels should be adequate to allow persons with impaired vision to navigate safely within the internal environment.
- 2.12.2 Sufficient lighting levels are required in areas where lip or sign reading may be required. Lighting should be designed to illuminate the face of the person to make it easier to lip or sign read.
- 2.12.3 Artificial lighting should give good colour rendering of all surfaces.
- 2.12.4 The information in Table 5 indicates the lighting levels required in accessible to all environments.

Table 5: Minimum lighting levels

Area	Minimum luminance (lx)
Reading rooms, offices	500
Assembly and conference rooms	300
Entrance halls and corridors, Canteens	200
Control devices (e.g., coin / card operated devices)	200
Toilets	150
Stairs/ramps/lifts	100
Bus shelters	100

2.13 Signage Guidelines

2.13.1 The location of signs should be part of the process of planning the building. They should be placed in a logical position and be obviously identifiable. Signs should be situated so that they do not cause obstruction.

2.13.2 Signs should be well lit and of non-glare finish type.

See guidelines on Lighting

2.13.3 Directional signs should indicate the route to a destination, paying particular attention to potential points of uncertainty.

2.13.4 Directional signs should be placed only on fixed parts of the building such as walls, posts and floors. The minimum headroom of directional signs suspended from ceilings or posts, or projected from walls should be 2m.

2.13.5 Detailed signs or instructions, especially safety notices should be duplicated at high and low level, at 1400mm to 1700mm for a visually impaired person when standing and 1000mm to 1100mm for convenient close viewing by a wheelchair user.

2.13.6 The height of lettering for visual signs should be chosen to suit the type of sign and the viewing distance in accordance with Table 6.

Table 6: Height of signs

Viewing distance	Type of sign	Letter height (mm)
Long distance	External fascia sign	200
	External location sign	90-120
	External direction signs	90
	House numbers	90
Medium distance	Location and direction	60
	Identification signs	40
Close range	Room identification signs	30
	Directories	15
	Wall mounted information	15

2.13.7 The character proportions of signs should be within the range of 3:5 to 1:1.

2.13.8 Signboards should contrast in colour and luminance with their backgrounds. Examples of colours for general signboards are shown in Table 7.

Table 7: Colour schemes for sign boards

General signboard	Background of general signboard	Text, symbols and pictograms
White	Dark	Black, dark green or dark blue
Black or dark	Light or stone colour	White or yellow
Black or dark	Whitewashed wall	White or yellow
White	Green vegetation	Black, dark green or dark blue.

NB. Light coloured text and symbols or pictograms on a dark background are preferred.

- 2.13.9 Where the required signboard colours match the wall colour and cannot be changed, a contrasting border should be placed around the sign, equal in width to at least half the letter height of the text used for the sign.
- 2.13.10 Directional signs and signs identifying functions or activities within a building should incorporate embossed letters in a sans serif type face with a depth of 1.25mm +/- 0.25mm, a stroke of 1.75mm +/-0.25mm, the edges slightly rounded but not half round in section, and a letter height of between 15mm and 50mm.
- 2.13.11 Where Braille is to be provided the following recommendations apply: Grade 1 Braille should be used for single word signs; and Grade 2 contracted Braille should be used to reduce the length of multi-word signs. A marker (e.g. a notch) should be located at the left hand edge of the sign to help locate the Braille message.
- 2.13.12 The international symbol of access must be adopted within all signs depicting this pictogram. The wheelchair figure must always face towards the right unless used in a directional sign indicating to the left (Figure 19).

Figure 18:
**International symbol
of access**



Figure 19:
**International symbol indicating
services for hearing impaired persons**



- 2.13.13 The outer dimensions of the square should be 65mm square for indoor applications with a visibility requirement of up to 9m. The outer dimensions should be 115mm square for door applications with visibility requirements greater than 9m and outdoors applications up to 18m. For applications where the visibility requirements exceed 18m, the outer dimensions should be 200mm square.
- 2.13.14 Accessible facilities for disabled people should be clearly marked in a manner that indicates the service provided for person with disability (Figures 18 and 19).
- 2.13.15 Symbols should be used to supplement written signs especially for sanitary facilities.
- 2.13.16 Visual signs should comprise simple words, clearly separated from one another and short sentences should be used to convey the required information.
- 2.13.17 Sentences or single word messages should begin with an upper case letter and continue with lower case letters. Words entirely in upper case (capital) should not be used.
- 2.13.18 Road signs should have the following characteristics:
- Type should have lines of uniform thickness
 - Type should have no flourishes
 - Underlining should be avoided
 - A large contrast between letters and their background, black lettering on a yellow background makes for good readability.
-
- 2.13.19 Road signs should be affixed at least 2m above the ground level, well lit and located as not to cause obstruction.
- 2.13.20 Written instructions should be accessible to people with visual impairment and should be at least of type 14.

2.14 Aural Environment Guidelines

Items
assessed
at design
drawing stage

- 2.14.1 In order to have full benefit of attending a public performance or playing a proper part in discussions, a person with impaired hearing needs to receive a signal some 20 dB higher than that received by a person with normal hearing. Whichever system is selected it should be capable of suppressing reverberation and audience and other environmental noise and provide sound without loss or distortion through bad acoustics or extraneous noise.
- 2.14.2 Aids to communications for the benefit of those with hearing aids are to be provided at:
- Booking and ticket offices and the like where the customer is separated from the vendor by a glazed screen.
 - In large reception rooms, auditoria, and meeting rooms in excess of 100m² in area.
- 2.14.3 Buzzers and bells to call for attention should incorporate a visible signal to indicate to the user that the buzzer has been pressed. Any internal audible alarm system in a building should be supplemented with an illuminating device to alert people with impaired hearing.
- 2.14.4 Public address systems should be clearly audible and, whenever practicable, supplemented by visual information.
- 2.14.5 Public address systems for performances and announcements should be amplified in a form that is suitable for people with impaired hearing.
- 2.14.6 The type and quality of microphones used for hearing enhancement systems, and their placement and proper maintenance, should be established at an early stage in the design of the building.
- 2.14.7 Rooms or spaces used for presentations should have line input sockets in accessible locations so that audio sound, or the speech dedicated channel of films, presentations or video soundtracks, can be fed into the transmitting equipment and should be sound treated to reduce reverberation.
- 2.14.8 A hearing enhancement system for hearing aid users, using induction loop, infrared or radio transmission, should be installed in rooms and spaces used for meetings, lectures, classes, performances, spectator sport or films, and at service or reception and counters where the background noise level is high or where glazed screens are used.
- 2.14.9 An induction loop system should be used in rooms or spaces where:
- A relatively simple, economical system benefiting any user of a suitable hearing aid is required;
 - There is no magnetic interference from electrical equipment in or near the room or space;

- Confidentiality or spill over of the loop signal to adjoining spaces is not an issue;
 - Issue/retrieval/maintenance/security of transmitters and receivers is not viable due to the function of the space or absence of on-site management.
- 2.14.10 A building should be designed to ensure that any spill over from one loop does not affect another loop, or compromise confidentiality. This is because induction loops are based on magnetic fields, transmissions can be picked up by other hearing aid users in adjacent rooms or spaces either side of a room, or on floors immediately above or below the space in which the induction loop is being used. This may be a problem in multi-screen cinemas and in locations where confidentiality is required, such as council chambers or courtrooms.
- 2.14.11 A room which provides acoustic characteristics having a reverberation time of 0.4 seconds will provide the optimum aural environment for speech clarity and should be provided in rooms where sound clarity is important, such as auditoriums, assembly halls, class rooms or lecture rooms.
- 2.14.12 Rooms in which the floor and walls are finished with soft surfaces (e.g. curtains and carpets) will provide an optimum aural environment for persons with impaired hearing and also for those with visual impairments who have to rely on the character of reflected sounds. Schools, should have at least one room on every floor in which the walls and floors are finished with materials with high sound absorbencies.



[P A R T I I I] Building Types Specific Design Guidelines

3.1 Industrial Buildings

Items
assessed
at design
drawing stage

These buildings should comply with sections 1 and 2 of the above Access for All Guidelines except for provisions made below.

3.1.1 Industrial development of new large premises (i.e., greater than 300 sqm, footprint area) shall be fully accessible to all.

3.1.2 Industrial development of new small premises (less than 300m² footprint area) shall have the ground floor fully accessible to all.

Provided that:

- All areas providing a customer service shall be fully accessible to all.
- Administration offices shall, if the building extends to a second level only, have at least a lift shaft that can accommodate a lift conforming to the
- Access for All guidelines.

3.1.3 Industrial development of new small premises (less than 300m² footprint area) shall, if the building extends to a second level only, have a lift shaft that can accommodate a lift conforming to the Access for All guidelines.

Provided that:

All areas providing a customer service shall be fully accessible to all. Administration offices shall, if the building extends to more than two levels, be fully accessible to all.

3.1.4 Industrial development of new small premises (less than 300m² footprint area) shall, if the building extends to more than two levels, be fully accessible to all.

3.1.5 Extensions, modifications, etc. of existing industrial premises shall have the ground floor fully accessible to all.

Provided that:

- All areas providing a customer service shall be fully accessible to all.
- Administration offices shall, if the building extends to a second level only, have a lift shaft that can accommodate a lift conforming to the Access for All guidelines.

3.1.6 Extensions, modifications, etc of existing industrial premises shall, if the building extends to a second level only, be exempted from having a lift shaft or a lift.

Provided that:

- All areas providing a customer service shall be fully accessible to all.
- Administration offices shall, if the building extends to a second level only, have a lift shaft that can accommodate a lift conforming to the Access for All guidelines.



3.1.7 Extensions, modifications, etc. of existing industrial premises shall, if the building extends to a third level only, have a lift shaft that can accommodate a lift conforming to the Access for All guidelines.

Provided that:

All areas providing a customer service shall be fully accessible to all.
Administration offices shall, if the building extends to more than two levels, be fully accessible to all.



3.1.8 Extensions, modifications, etc. of existing industrial premises shall, if the building extends to more than three levels, be accessible to all.



3.1.9 In areas where a service is provided to the public, this part of the development shall be fully accessible to all.



3.2 Bus Shelters

- These buildings should comply with sections 1 and 2 of the above Access for All Guidelines except for provisions made below.
- 3.2.1 Bus shelters should be located in such a way and in a location to ensure that they are accessible to all.
- 3.2.2 Shelters are to be designed without appendages protruding from the external perimeter that may lead to tripping or collision.
- 3.2.3 Shelters are to be well lit at all times.
See guidelines on Lighting
- 3.2.4 Tunnel type shelters, i.e. having the two longer sides enclosed, are to have a minimum internal clear width of 1000mm.
- 3.2.5 Sufficient space, not less than 900mm width, is to be provided below the covered area for at least one wheelchair user. For this purpose, the bench is not to occupy the full length of the shelter.
- 3.2.6 Glass panelling should be such as to permit wheelchairs users to be able to see oncoming buses.
- 3.2.7 Seats are not to be higher than 500mm and armrest, if any, are not to be higher than 700mm from ground level.
- 3.2.8 Information panels with bus routes and time-tables are to be located 1500mm to 1700mm high above ground level and are to be printed at least in point size 12. Glass surfaces are to be clearly marked with suitable manifestation marks. Advertising panels placed at right angles to the pavement are to be lit internally.
See guidelines on Lighting
See guidelines on Signage
- 3.2.9 A minimum width of pavement of 1000mm clear must be left free from obstacles (e.g. traffic signs and garbage bins) to access the shelter at least from one side. A turning circle of 1500mm should be provided in all circumstances where a wheelchair user is required to manoeuvre through a 90 degree or 180 degree turn to access the bus shelter.
- 3.2.10 Bus shelters should be outside the main line of travel of pedestrian flow.
- 3.2.11 Shelters are to be located well clear of pedestrian crossings at street corners, whether controlled or uncontrolled.
- 3.2.12 Shelters are not to obstruct view of pedestrian crossing from approaching vehicles.
- 3.2.13 Surface below shelter must be uniform and even, providing a smooth surface that is level with the pavement. Materials for paving are to be of the non-slip type.
See guidelines on Surfaces

Items assessed at design drawing stage

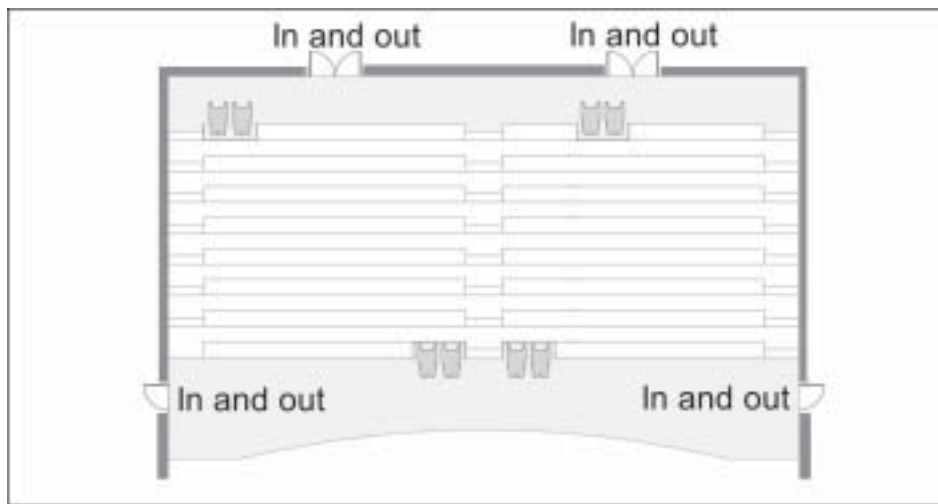
3.3 Assembly Areas (Theatres, Auditoria, etc.)

These buildings should comply with sections 1 and 2 of the above Access for All Guidelines except for provisions made below.

- 3.3.1 The route from the entrance of the building to all facilities should be fully accessible to all.
- 3.3.2 The provision of wheelchair spaces in audience seating should be as shown in the Table 8 and laid out in accordance with Figure 20 according to the particular number of wheelchair spaces required and the assembly area layout.

Audience seating capacity	Number of seats suitable for wheelchair users
less than 25	1
26-250	2
251-500	3
501-750	4
750+	2+1 per 250 or part thereof

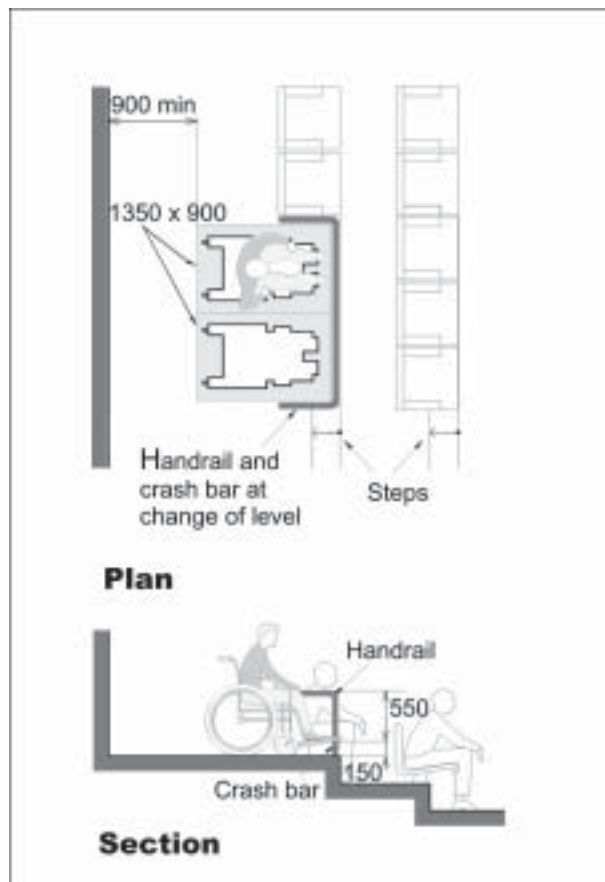
Figure 20: Details of seating arrangements for wheelchair users in auditoria



- 3.3.3 A wheelchair space should be provided with a clear view of the event. In assembly areas with a raked floor, a choice of space should be provided as shown in Figure 21. Sight lines should allow a view of projection screens and high level electronic text devices as well as people assisting with sign language.

- 3.3.4 Wheelchair spaces should be designed and located in such a way that their occupants may sit adjacent to companions with or without disability.
- 3.3.5 The stage, podium as well as all other facilities such as dressing rooms should be accessible to persons with disability.
- 3.3.6 As an alternative to standard seating, consideration should be given to the provision of perching seats, either fixed or pull down, with and without backs.
- 3.3.7 Seating for persons with disability should not obstruct participants, or other members of the audience.
- 3.3.8 Seating should contrast in colour and luminance with the surrounding surfaces.
- 3.3.9 Sloping access routes should conform to Ramps Guidelines contained in this document.
- 3.3.10 In places of worship and religious buildings, such as churches, access for wheelchair users should be provided to all amenities of major use, including altars.

Figure 21: Details of seating arrangements for wheelchair users in auditoria



3.4 Business and Refreshment Buildings (Restaurants, Cafè's, Bars)







Items
assessed
at design
drawing stage

These buildings should comply with sections 1 and 2 of the above Access for All Guidelines except for provisions made below.

- 3.4.1 The full range of services offered in new buildings and in any building that has a gross floor area greater than 150m² shall be accessible to all.
- 3.4.2 Outlets in existing buildings having a gross floor area between 75m² and 150m² must have, at least, the main entrance accessible to all as well as having accessible to all sanitary facilities. Provided that at least 50% of any area where a service is provided is accessible to all.
- 3.4.3 Outlets in existing buildings having a gross floor area less than 75m² must have, at least, the main entrance accessible to all. Provided that at least 50% of any area where a service is provided is accessible to all.
- 3.4.4 Where there are changes in floor level, reasonable provision for access should be made by keeping them to a reasonable scale and permitting access for the ambulant disabled, and at least half of each facility available to wheelchair users.
- 3.4.5 A self service area should have a continuous counter at a height of 850mm to allow a disabled person to manoeuvre a tray and a suitable table should be provided within close proximity of the till.
- See guidelines on Counters*
- 3.4.6 The clearance between furniture and fittings should be sufficient to allow wheelchair users a choice of seating location and to circulate freely to all amenities.

3.5 Facilities providing accommodation for the public (e.g. Hotels, residences for the elderly and so on).

These buildings should comply with sections 1 and 2 of the above Access for All Guidelines except for provisions made below.

- 3.5.1 All common facilities such as dining rooms, reading rooms etc. shall be accessible to all. 
- 3.5.2 In facilities providing accommodation for the public the following provisions shall be made in respect of bedrooms:
- One guest bedroom out of every twenty guest bedrooms (or part thereof) shall be suitable, in terms of dimensions and layout, for use by a person using a wheelchair.
 - The entrance door to wheelchair accessible bedroom shall be accessible to all.
 - The entrance door to any other guest bedroom shall have a clear opening width of at least 850mm but with the option to dispense with the 300mm space at the side of the door.
 - Bathroom facilities in guest bedrooms that are suitable for use by a person in a wheelchair shall be en suite if that is the arrangement for the remainder of the bedrooms and should include shower facilities whereby a wheelchair user is not required to get off the wheelchair to use the shower. 
- 3.5.3 Wheelchair-accessible bedrooms should be sufficiently spacious to enable a wheelchair user to transfer to one side of a bed without assistance. 
- 3.5.4 Wheelchair accessible rooms should have an accessible balcony where such a facility is provided in other rooms. 
- 3.5.5 Wheelchair accessible rooms should have a connecting door to an adjacent bedroom. 
- 3.5.6 In residences primarily for the elderly:
- All bedrooms should be accessible to all.
 - All facilities that are for common use should be accessible to all.
 - 50% of all bedrooms with ensuite facilities should have the bathrooms accessible to all including walk in showers. 

Items assessed
at design drawing stage

3.6 Residential buildings

- 3.6.1 All common areas such as entrances, garages, lobbies, lifts etc shall be accessible to all.
- 3.6.2 The ground floor residential units in large residential developments, i.e. those containing more than 30 residential units (20 residential units after January 1st 2008), should be designed to be accessible to all.



3.7 Beaches and Swimming Pools

Items
assessed
at design
drawing stage

- These developments should comply with sections 1 and 2 of the above Access for All Guidelines except for provisions made below.
- 3.7.1 Public access to beaches and normally accessible foreshores should be accessible to all.
- 3.7.2 Beaches should be provided with paths that can easily be used by persons using a wheelchair. These paths should be provided from accessible to all areas of the beach to the waterline.
- 3.7.3 Facilities provided on beaches and the foreshore, such as refreshment kiosks and toilets / showers should be accessible to all.
- 3.7.4 Facilities should be provided that allow persons with disability, particularly wheelchair users, safe and easy access to the water. These facilities may include ramps, rails and so on.
See guidelines on Ramps
- 3.7.5 An accessible to all route should be provided from parking areas to the beach.
- 3.7.6 Level access should be provided from changing areas to pool areas.
- 3.7.7 Access to the pool for wheelchair users should be provided. A hoist which allows transfer from the wheelchair to the pool should be provided.
- 3.7.8 The area around the pool should have a non-slip surface.
See guidelines on Surfaces

3.8 Offices (used solely as workplaces and providing no services to the public)

Items
assessed
at design
drawing stage

These buildings should comply with sections 1 and 2 of the above Access for All Guidelines except for provisions made below.

- 3.8.1 Any office building in a new building or that has a gross floor area greater than 150m² shall be accessible to all.
- 3.8.2 Offices in existing buildings, having a gross floor area between 76m² and 150m² must have, at least, the main entrance accessible to all as well as having accessible to all sanitary facilities.
- 3.8.3 Offices in existing buildings, having a gross floor area between 30m² and 75m² must have, at least, the main entrance accessible to all.
- 3.8.4 Offices in existing buildings, having a gross floor area less than 30m² are exempt.

Glossary

Accessible	Able to be accessed by persons with disability.
Accessible route	Any route that is used to approach, or move between or within a building, and is accessible to disabled people.
Chair stairlift	Lift that travels from one level to another along a line parallel with the pitch line of the stair and incorporates a chair. Such a lift is not considered an acceptable means of providing Access for All in a building open to the public.
Effective clear width	Available width measured at 90 degrees to the plane of the doorway for passage through a door opening, clear of all obstructions, such as handles and weather boards on the face of a hinged door, when such a door is opened through 90 degrees or more, or when a sliding or folding door is opened to its fullest extent.
Flight	Ramp or a continuous series of steps between two landings.
Going	Horizontal distance between two consecutive nosings of a step, measured on the walk-line or the horizontal distance between the start and finish of a flight of a ramp.
Handrail	Component of stairs, steps or ramps that provides guidance and support at hand level.
Illuminance	Amount of light falling on a surface, measured in lumens per square metre (lm/m^2) or lux (lx).
Landing	Platform or part of a floor structure at the end of a flight or ramp, or to give access to a lift.
Luminance	Brightness or light intensity of a surface, measured in candelas per square metre (cd/m^2).
Nosing	Projecting front edge of a tread or landing that may be rounded, chamfered or otherwise shaped.

Platform lift	Lift with, a platform and low walls and which travels vertically between two levels and is intended for use standing up or seated on a chair or a wheelchair
Principal entrance	Entrance to a building that a visitor or staff member would normally expect to approach.
Ramp	Construction, in the form of an inclined plane 1:20 or steeper from the horizontal or a series of such planes and an intermediate landing or intermediate landings that make it possible to pass from one level to another.
Rise	Vertical distance between the upper horizontal surfaces of two consecutive treads, or of a landing and the next tread above or below it, or of a flight between two consecutive landings.
Riser	Vertical component of a step between tread or landing or the tread or landing above or below it.
Stair clear width	Unobstructed minimum distance on plan perpendicular to the walking line of a stair.
Stair platform lift	Lift that travels from one level to another along a line parallel with the pitch line of the stair and incorporates a horizontal platform that accommodates a wheelchair user.
Tactile paving	Profiled paving surface providing guidance or warning to blind and partially sighted people.
Tread	Horizontal component of a step.
Unisex	Facility designed for use by either sex with or without assistance by people of the same or opposite sex.